



(19) **United States**

(12) **Patent Application Publication**

Lee et al.

(10) **Pub. No.: US 2014/0014929 A1**

(43) **Pub. Date: Jan. 16, 2014**

(54) **ORGANIC LAYER DEPOSITION APPARATUS, METHOD OF MANUFACTURING ORGANIC LIGHT-EMITTING DISPLAY APPARATUS USING THE SAME, AND ORGANIC LIGHT-EMITTING DISPLAY APPARATUS MANUFACTURED USING THE METHOD**

**Publication Classification**

(51) **Int. Cl.**  
*H01L 51/56* (2006.01)  
*H01L 27/32* (2006.01)  
(52) **U.S. Cl.**  
CPC ..... *H01L 51/56* (2013.01); *H01L 27/32* (2013.01)  
USPC ..... **257/40**; 438/46; 118/500

(71) Applicant: **SAMSUNG DISPLAY CO., LTD.**,  
Yongin City (KR)

(72) Inventors: **Su-Hwan Lee**, Yongin-City (KR);  
**Un-Cheol Sung**, Yongin-City (KR);  
**Chae-Woong Kim**, Yongin-City (KR);  
**Young-Mook Choi**, Yongin-City (KR)

(73) Assignee: **SAMSUNG DISPLAY CO., LTD.**,  
Yongin City (KR)

(21) Appl. No.: **13/938,173**

(22) Filed: **Jul. 9, 2013**

(30) **Foreign Application Priority Data**

Jul. 10, 2012 (KR) ..... 10-2012-0075138  
Jul. 13, 2012 (KR) ..... 10-2012-0076940  
Oct. 4, 2012 (KR) ..... 10-2012-0110095

(57) **ABSTRACT**

An organic layer deposition apparatus, a method of manufacturing an organic light-emitting display apparatus by using the same, and an organic light-emitting display apparatus manufactured using the method. The organic layer deposition apparatus includes a conveyer unit including first and second conveyer units, loading and unloading units, and a deposition unit. A transfer unit moves between the first and second conveyer units, and the substrate attached to the transfer unit is spaced from a plurality of organic layer deposition assemblies of the deposition unit while being transferred by the first conveyer unit. The organic layer deposition assemblies include common layer deposition assemblies and pattern layer deposition assemblies.

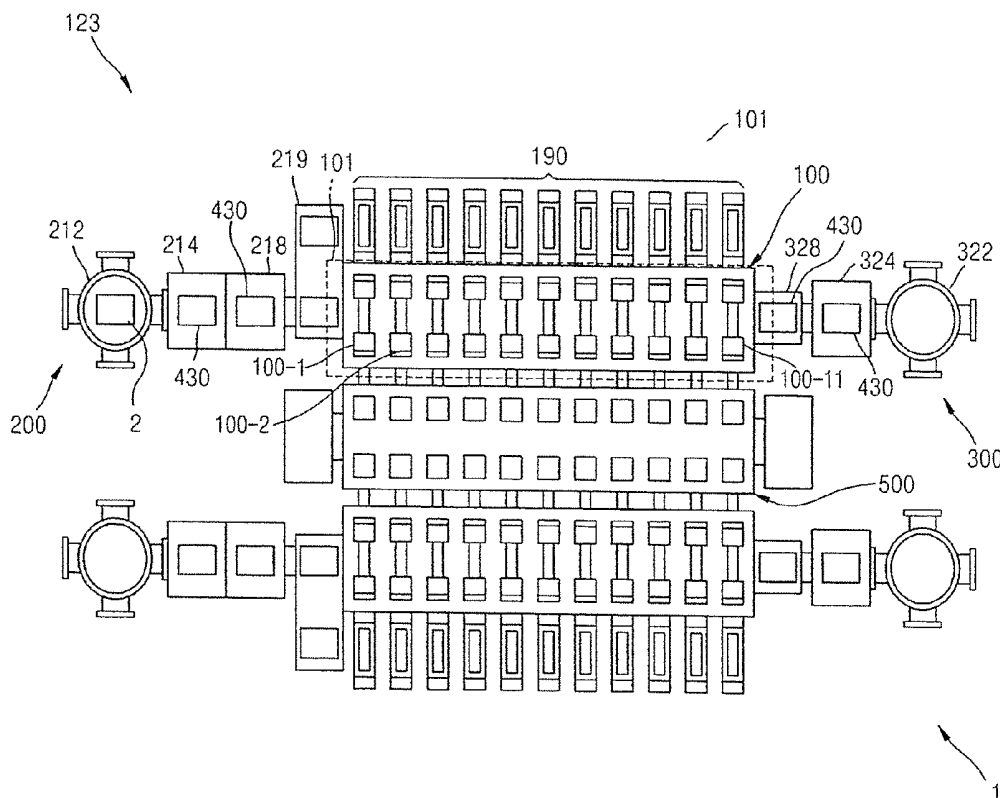



FIG. 2

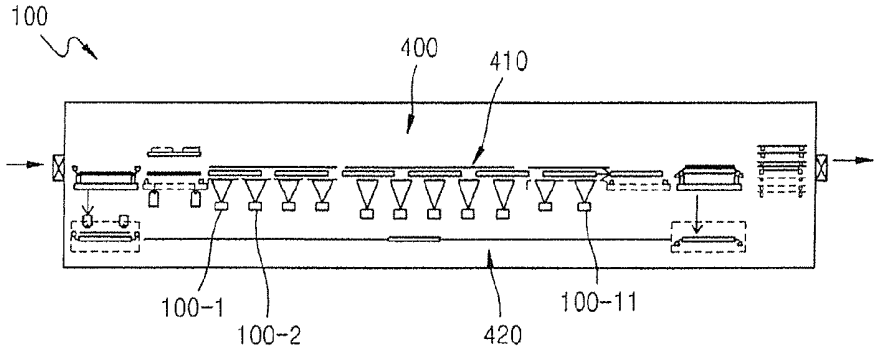

FIG. 3

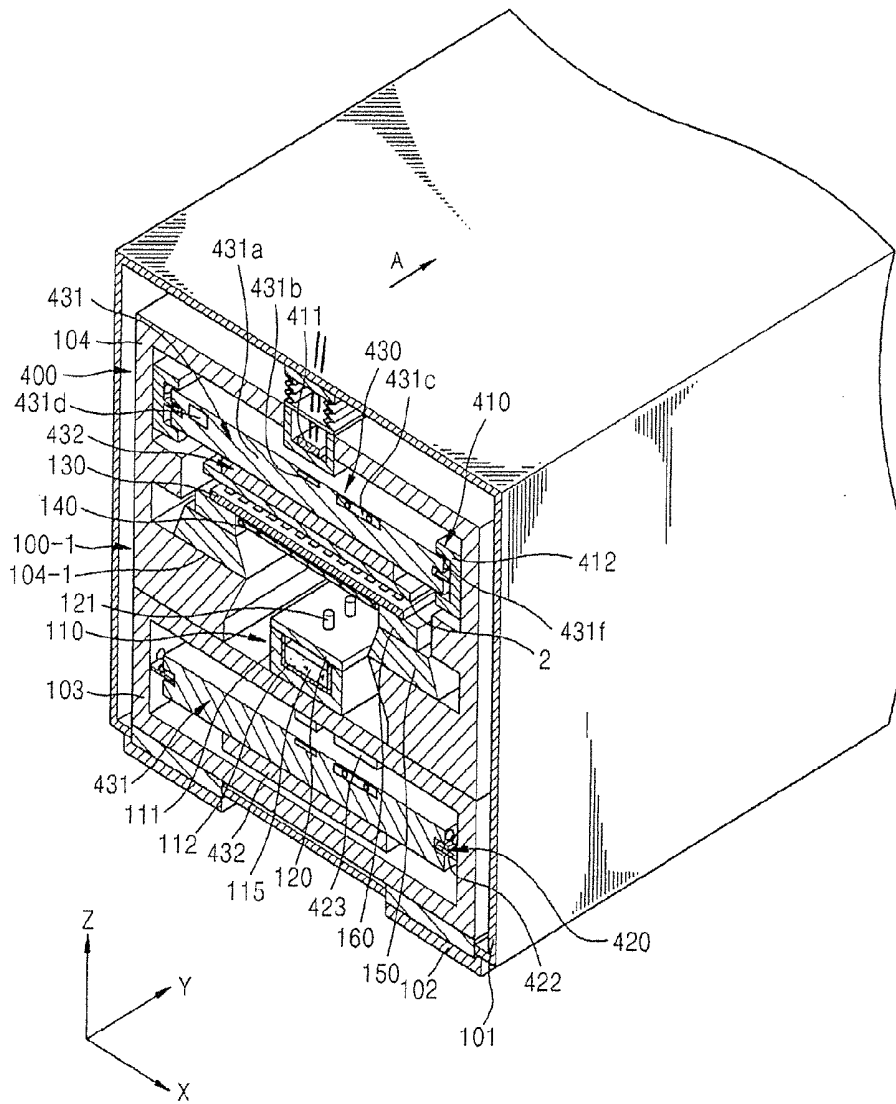

FIG. 4

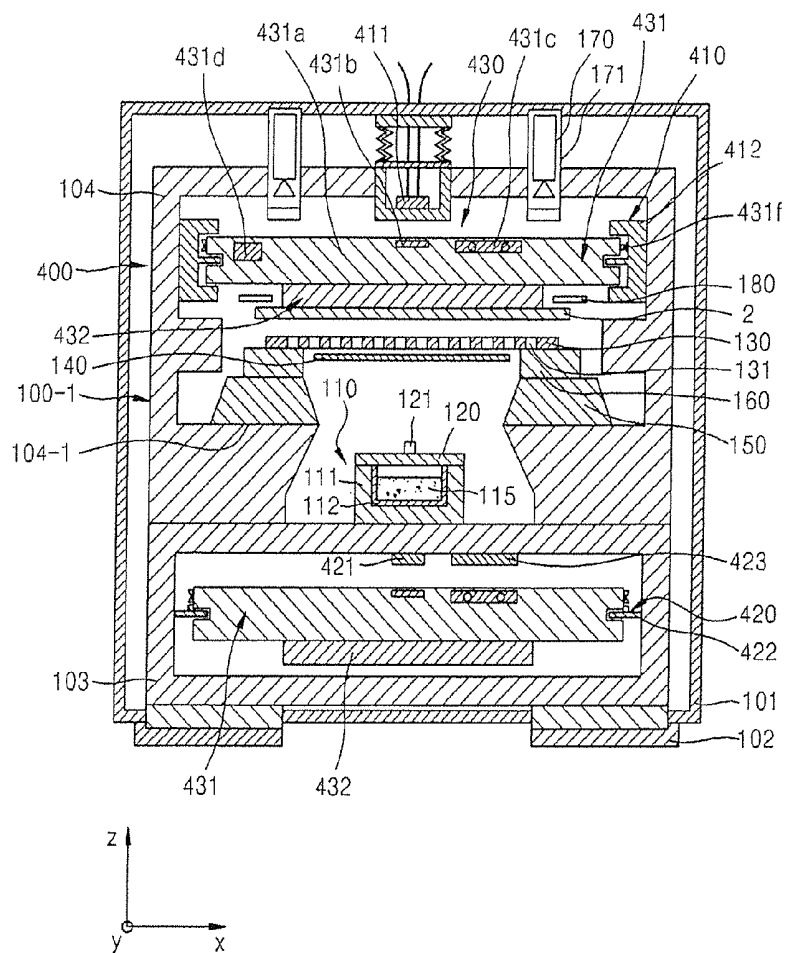

FIG. 5

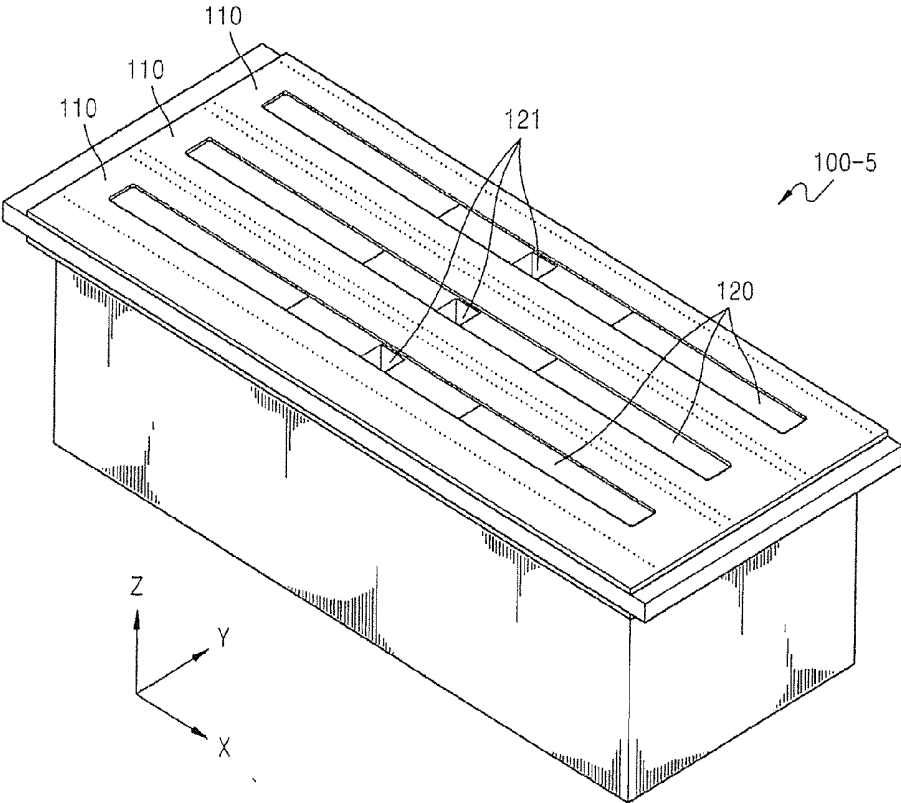

FIG. 6

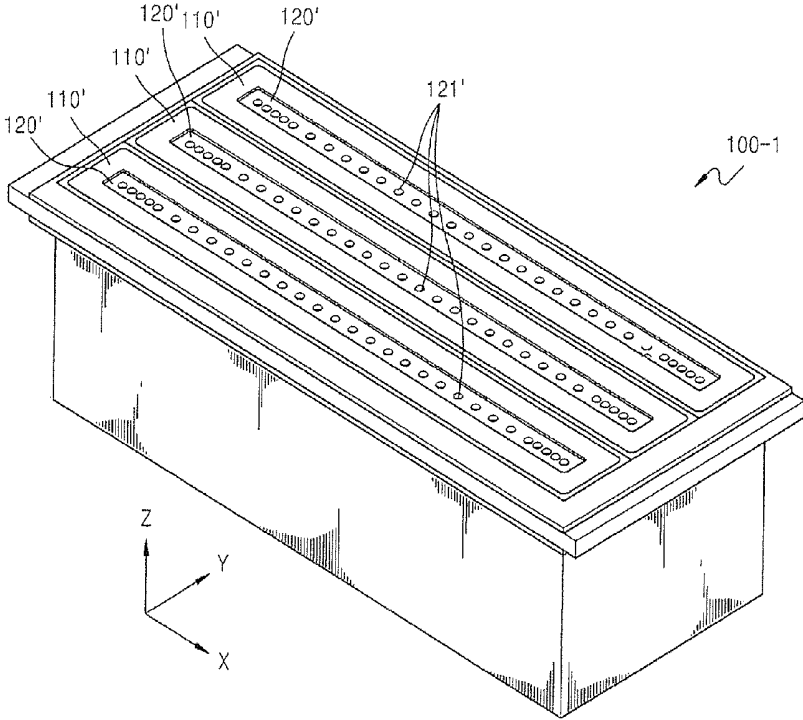



FIG. 8

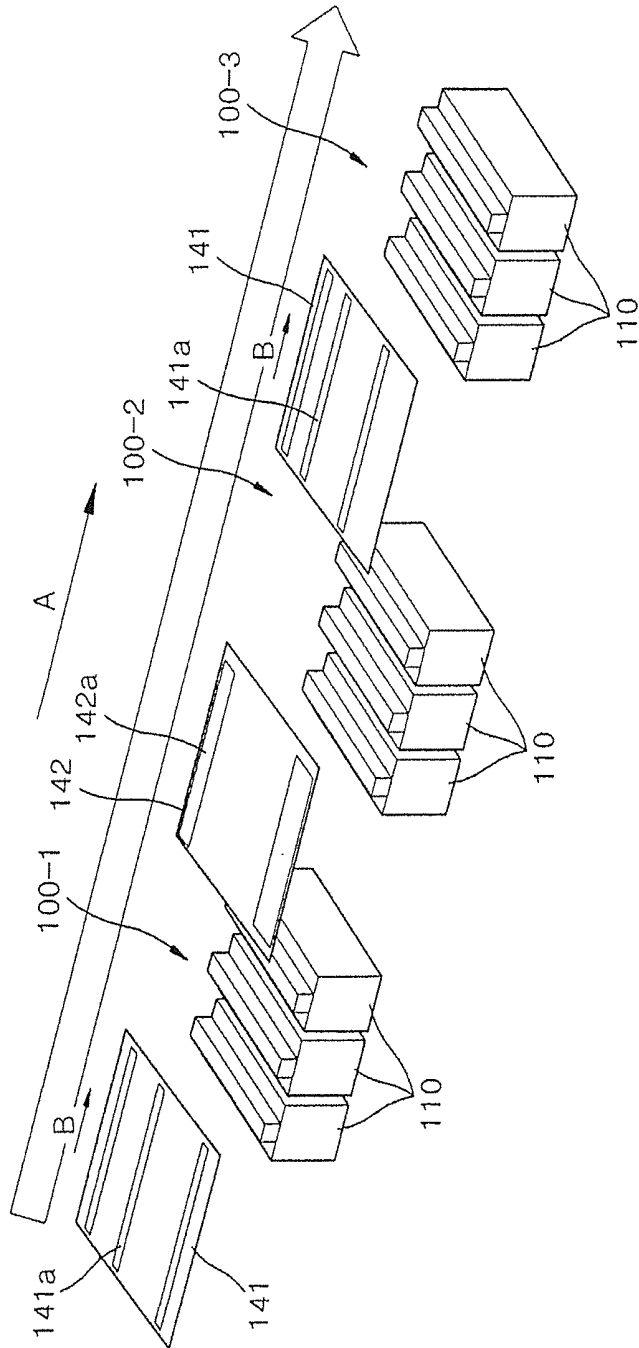

FIG. 9

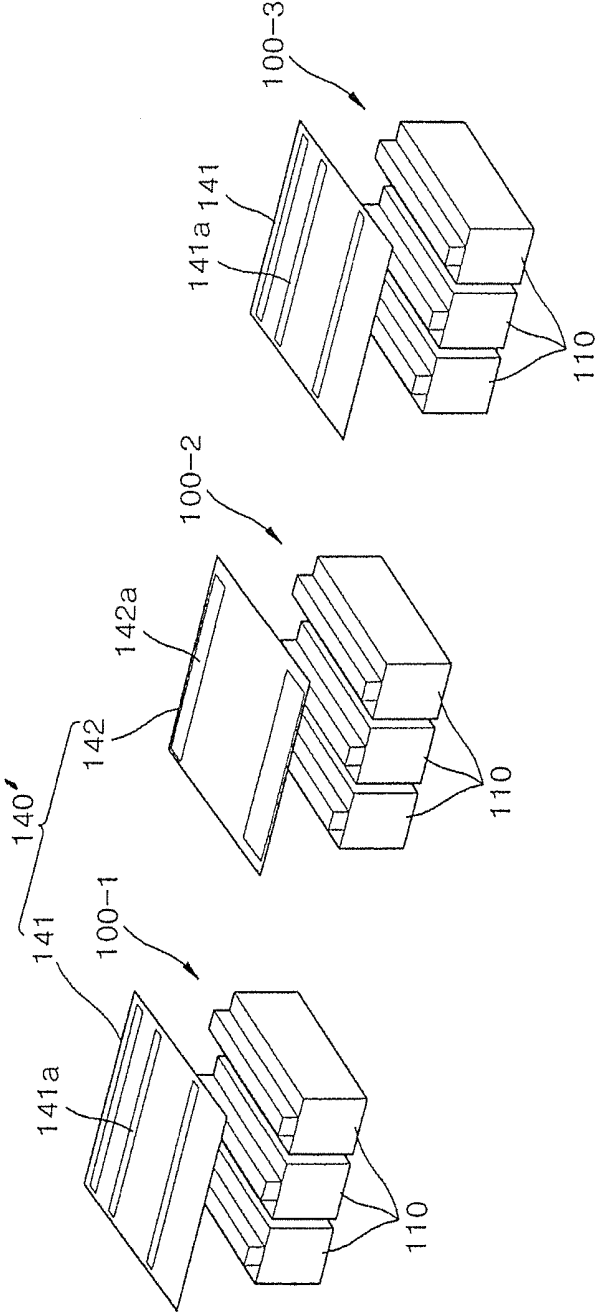

FIG. 10

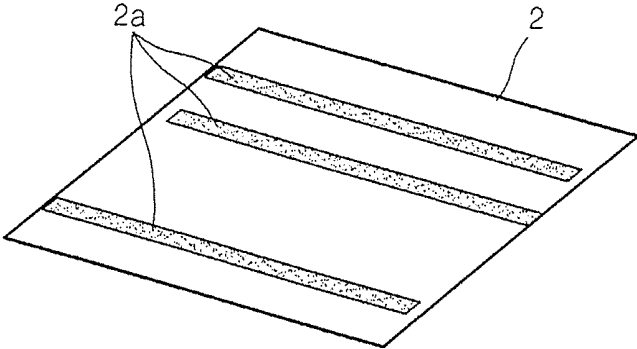

FIG. 11

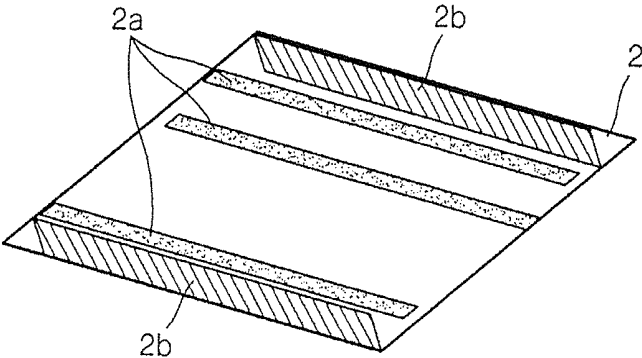

FIG. 12

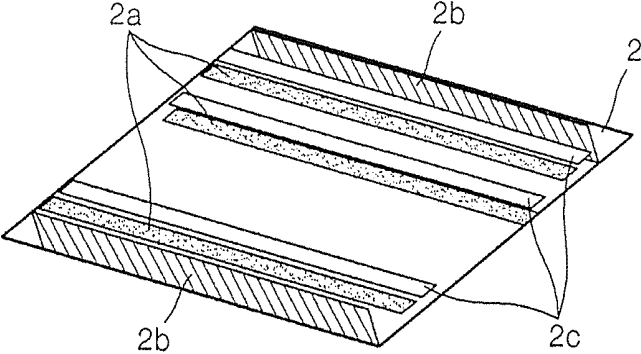

FIG. 13

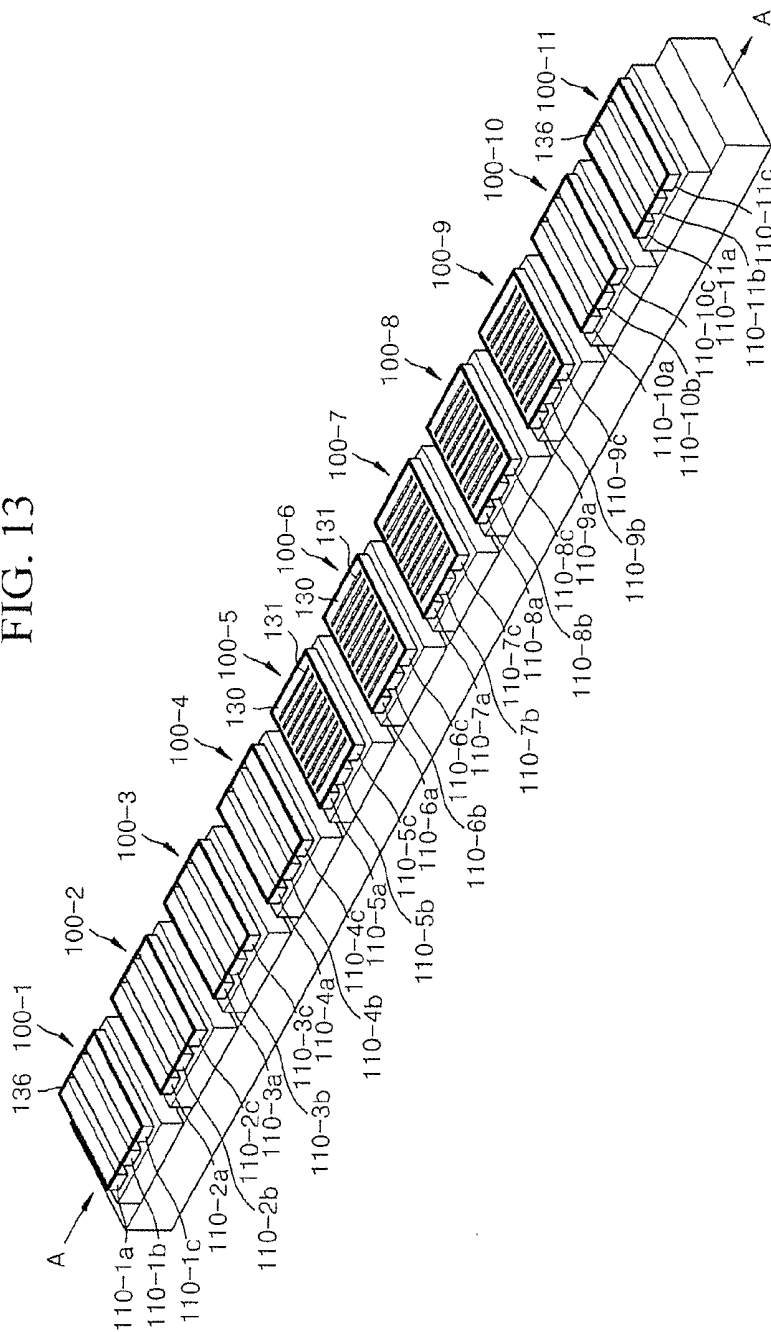

FIG. 14

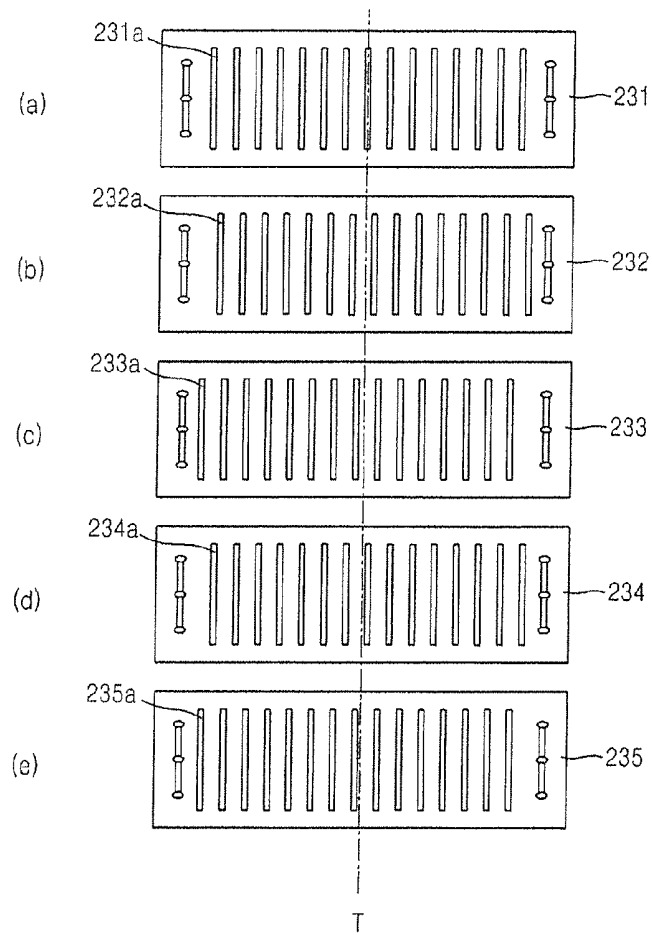

FIG. 15

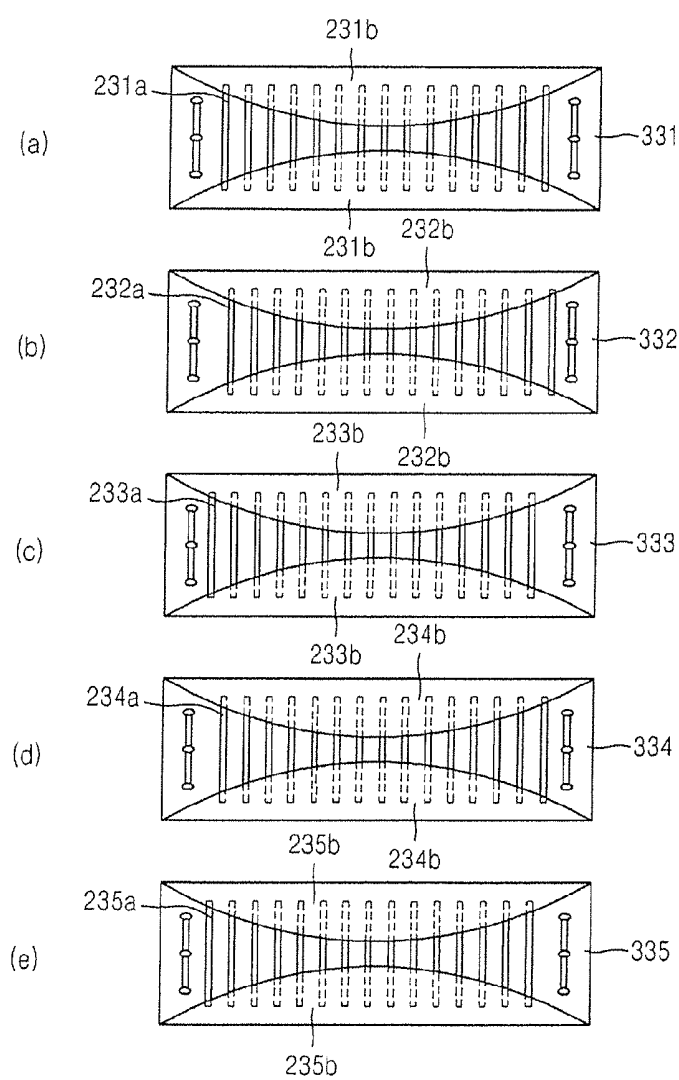



FIG. 17

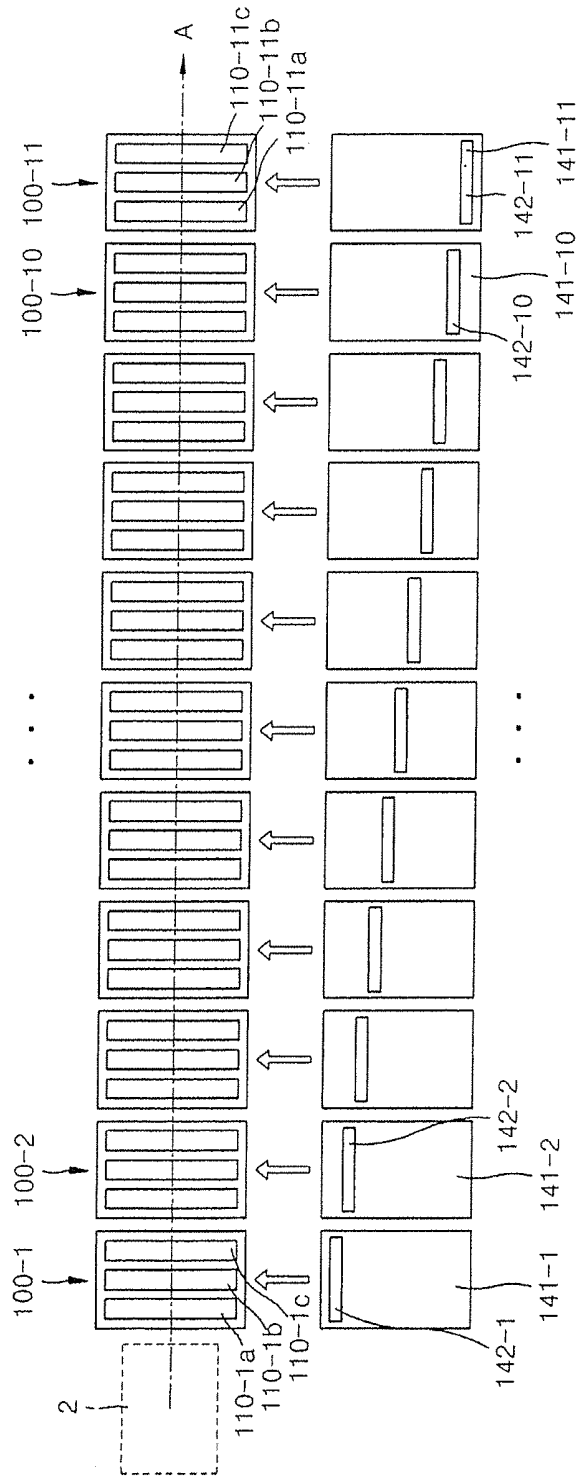

FIG. 18

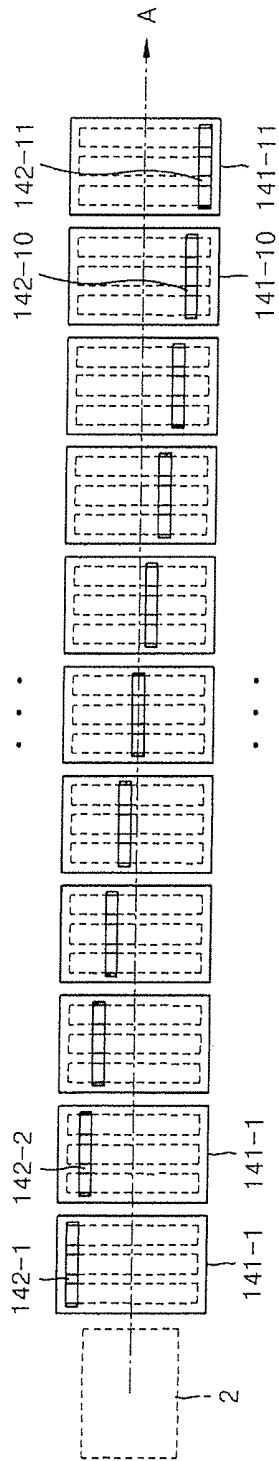

FIG. 19

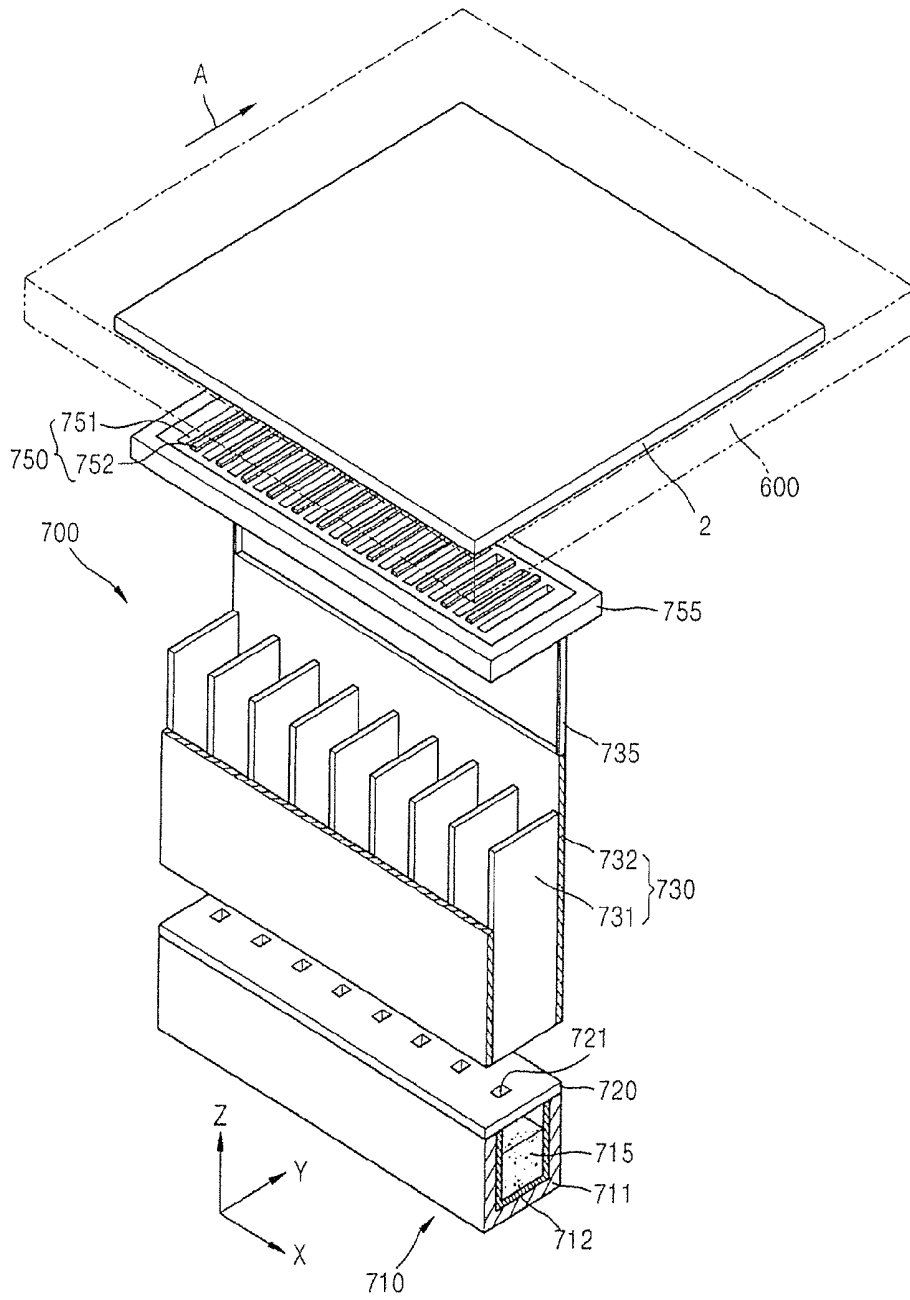

FIG. 20

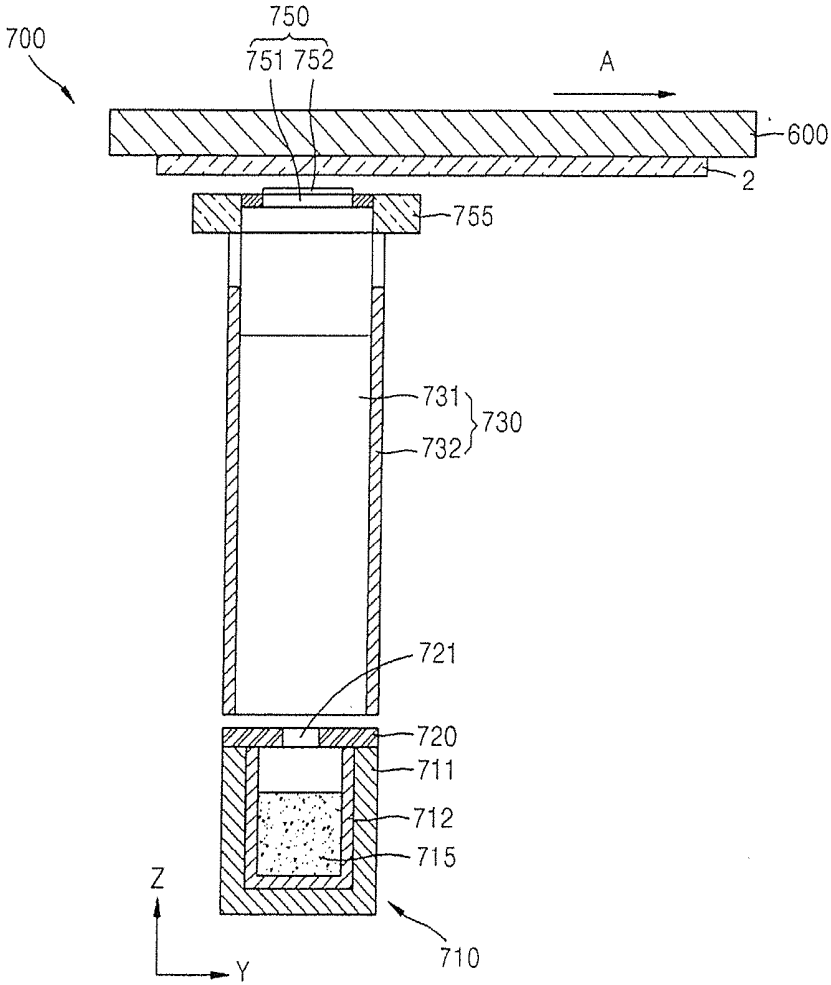

FIG. 21

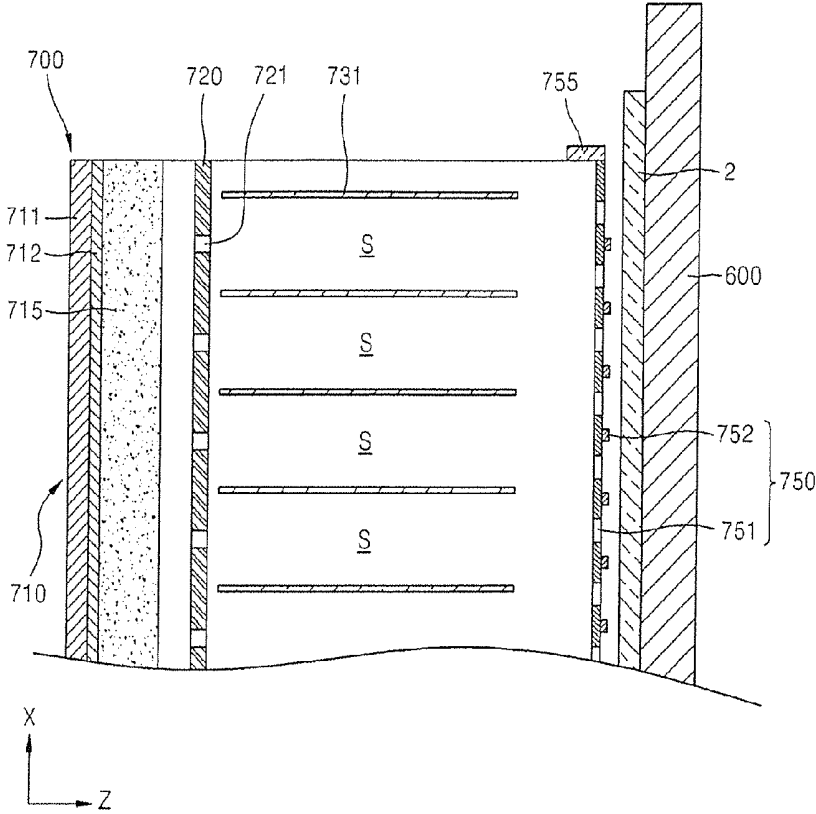

FIG. 22

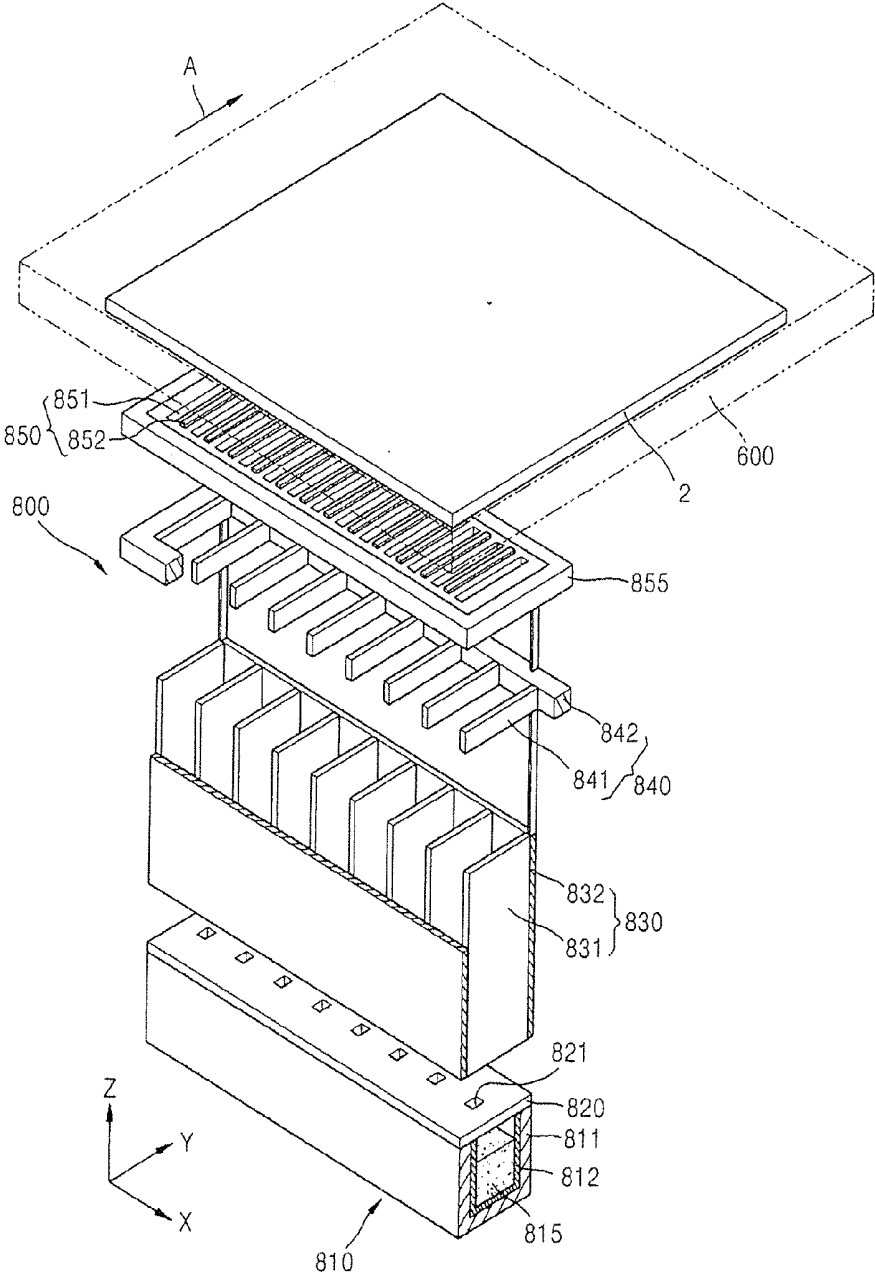

FIG. 23

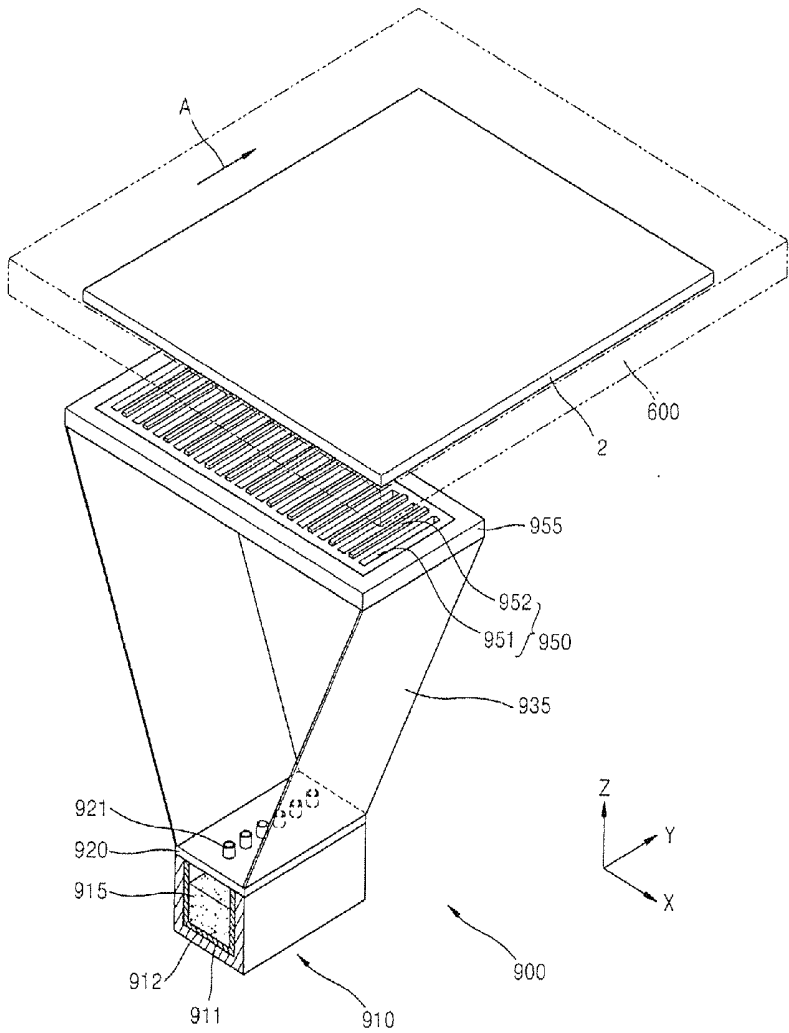

FIG. 24

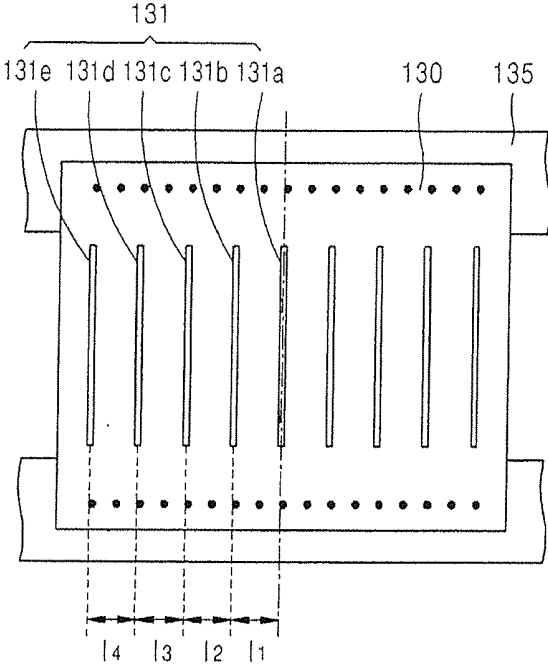

FIG. 25

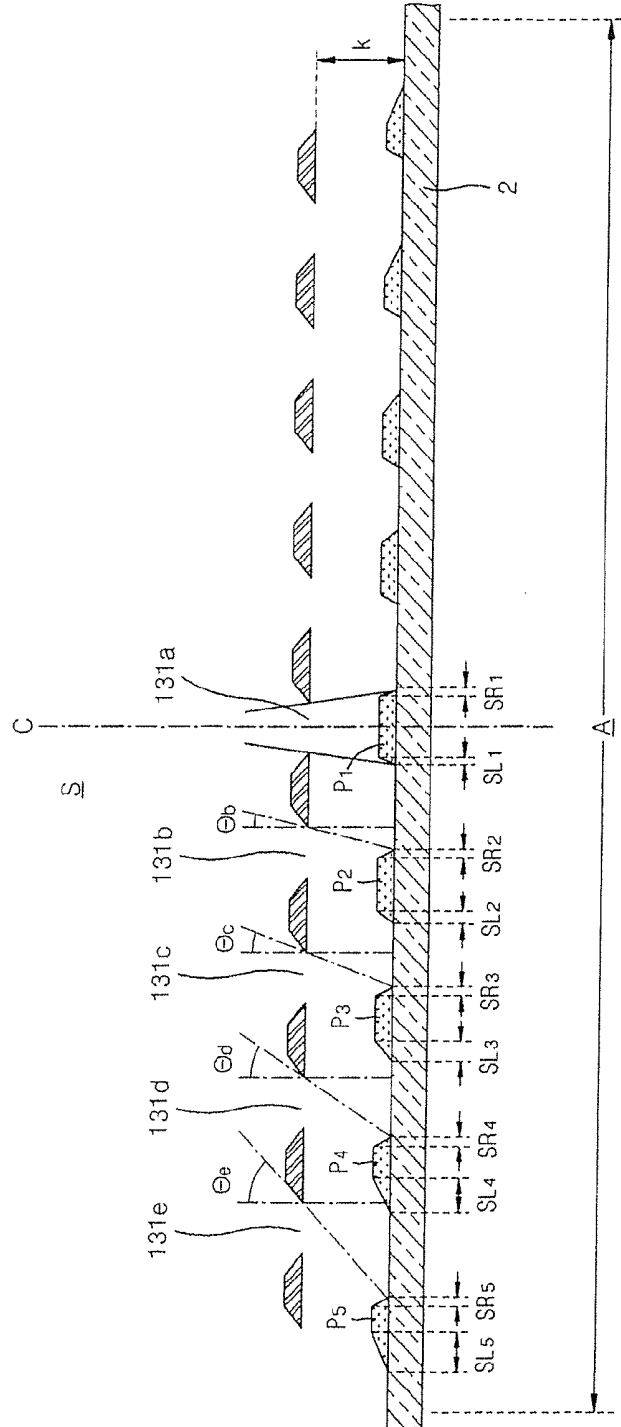
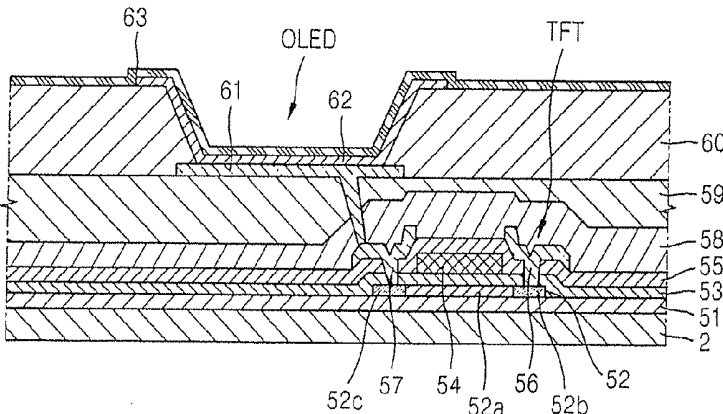

FIG. 26



**ORGANIC LAYER DEPOSITION  
APPARATUS, METHOD OF  
MANUFACTURING ORGANIC  
LIGHT-EMITTING DISPLAY APPARATUS  
USING THE SAME, AND ORGANIC  
LIGHT-EMITTING DISPLAY APPARATUS  
MANUFACTURED USING THE METHOD**

CROSS-REFERENCE TO RELATED  
APPLICATIONS

[0001] This application claims priority to and the benefit of Korean Patent Application No. 10-2012-0075138, filed on Jul. 10, 2012 in the Korean Intellectual Property Office, Korean Patent Application No. 10-2012-0076940, filed on Jul. 13, 2012 in the Korean Intellectual Property Office, and Korean Patent Application No. 10-2012-0110095, filed on Oct. 4, 2012 in the Korean Intellectual Property Office. The entire contents of all three cross-referenced applications are incorporated herein by reference.

BACKGROUND

[0002] 1. Field

[0003] Aspects of embodiments of the present invention relate to an organic layer deposition apparatus, a method of manufacturing an organic light-emitting display apparatus (organic light-emitting display device) by using the same, and an organic light-emitting display apparatus manufactured using the method.

[0004] 2. Description of the Related Art

[0005] Organic light-emitting display apparatuses (organic light-emitting display devices) have wider viewing angles, better contrast characteristics, and faster response speeds than other display devices, and thus they have drawn attention as a next-generation display device.

[0006] An organic light-emitting display apparatus includes intermediate layers, which include an emission layer, located between a first electrode and a second electrode facing the first electrode. The electrodes and the intermediate layers may be formed using various methods, one of which is an independent deposition method. When an organic light-emitting display apparatus is manufactured using a deposition method, a fine metal mask (FMM) having the same pattern as that of an organic layer to be formed is positioned to closely contact a substrate on which the organic layer and the like are to be formed, and an organic layer material is deposited through the FMM to form an organic layer having a desired pattern.

[0007] However, the deposition method using such an FMM presents difficulties in manufacturing large organic light-emitting display apparatuses using a large mother glass. For example, when a large mask is used, the mask may bend due to its own weight (self-gravity) to thereby distort a pattern. Such disadvantages might make the FMM method undesirable in view of the recent trend towards high-definition patterns.

[0008] Moreover, processes of aligning a substrate and an FMM to closely contact each other, performing deposition thereon, and separating the FMM from the substrate are time-consuming, resulting in a long manufacturing time, and may result in low production efficiency.

[0009] Information disclosed in this Background section was already known by the inventors of the present invention before achieving the present invention or is technical infor-

mation acquired in the process of achieving the present invention. Therefore, it may contain information that does not form the prior art that is already known in this country to a person of ordinary skill in the art.

SUMMARY

[0010] In order to address the drawback of the deposition method using a fine metal mask (FMM) and/or other issues, aspects of the present invention are directed toward organic layer deposition apparatuses that are suitable for use in the mass production of a large substrate, enable high-definition patterning, and reduce time and costs for the correction/compensating for a thickness of an organic layer, methods of manufacturing organic light-emitting display apparatuses (organic light-emitting display devices) by using the same, and organic light-emitting display apparatuses manufactured using the methods.

[0011] According to an embodiment of the present invention, an organic layer deposition apparatus is provided. The organic layer deposition apparatus includes: a conveyer unit including a transfer unit for attaching a substrate and configured to move along with the substrate, a first conveyer unit for moving in a first direction the transfer unit on which the substrate is attached, and a second conveyer unit for moving in a direction opposite to the first direction the transfer unit from which the substrate is separated after deposition has been completed; a loading unit for attaching the substrate on the transfer unit; a deposition unit including a chamber configured to be maintained in a vacuum state and a plurality of organic layer deposition assemblies for depositing an organic layer on the substrate attached to the transfer unit transferred from the loading unit; and an unloading unit for separating, from the transfer unit, the substrate on which the deposition has been completed while passing through the deposition unit, wherein the transfer unit is configured to move between the first conveyer unit and the second conveyer unit, the transfer unit is configured for the attached substrate to be spaced from the plurality of organic layer deposition assemblies while being transferred by the first conveyer unit, each of the plurality of organic layer deposition assemblies includes: a plurality of deposition sources, each of the plurality of deposition sources being configured to discharge a corresponding one of a plurality of deposition materials; and a deposition source nozzle unit at a side of each of the deposition sources, and including one or more deposition source nozzles, the organic layer deposition assemblies include a plurality of common layer deposition assemblies for forming a common layer and a plurality of pattern layer deposition assemblies for forming a pattern layer, each of the pattern layer deposition assemblies further includes a correction slit sheet including a plurality of correction slits, correction slits of the pattern layer deposition assemblies are offset with respect to each other along the first direction, and the deposition materials discharged from the deposition sources pass through respective said correction slit sheets and are deposited in a pattern on the substrate.

[0012] In one embodiment, each of the correction slits extends in the first direction.

[0013] Locations of the correction slits of the correction slit sheets in different pattern layer deposition assemblies may be different from each other in the first direction.

[0014] Pattern layers deposited on the substrate through the correction slit sheets may not overlap each other.

[0015] The correction slits of the correction slit sheets may have equal lengths.

[0016] The correction slits of the correction slit sheets may have different lengths.

[0017] A length of the correction slits of the correction slit sheets may increase as the correction slits are farther away from respective centers of the correction slit sheets.

[0018] The organic layer deposition apparatus may further include a correction plate located at a side of a corresponding one of the correction slit sheets and shielding at least a portion of the deposition material discharged from the deposition source.

[0019] A width of the correction plate may decrease from a center towards an edge of a corresponding one of the correction slit sheets.

[0020] The correction plate may have a shape of a circular arc or cosine.

[0021] A width of the correction plate at a region corresponding to a center of a corresponding one of the correction slit sheets may be greater than that at an edge of the correction plate.

[0022] The correction plate may have a shape such that the deposition material is better shielded at a center of the correction slit sheet than at an edge of the correction slit sheet.

[0023] The first conveyer unit and the second conveyer unit may be configured to pass through the deposition unit.

[0024] The first conveyer unit and the second conveyer unit may be arranged one on top of the other and may be parallel to each other.

[0025] The first conveyer unit may be configured to move the transfer unit to sequentially pass through the loading unit, the deposition unit, and the unloading unit in that order.

[0026] The second conveyer unit may be configured to move the transfer unit to sequentially pass through the unloading unit, the deposition unit, and the loading unit in this stated order.

[0027] A length of the correction slit sheets of the organic layer deposition assemblies in at least one of the first direction or the second direction may be smaller than that of the substrate.

[0028] According to another embodiment of the present invention, a method of manufacturing an organic light-emitting display apparatus by using an organic layer deposition apparatus for forming an organic layer on a substrate, is provided. The method includes: attaching a substrate to a transfer unit in a loading unit; transporting, into a chamber, the transfer unit to which the substrate is attached, by using a first conveyer unit passing through the chamber; depositing deposition materials discharged from a plurality of organic layer deposition assemblies to form organic layers on the substrate while the substrate is moved relative to the organic layer deposition assemblies, the organic layer deposition assemblies being in the chamber and spaced apart from the substrate; separating from the transfer unit the substrate on which the depositing has been completed in an unloading unit; and transporting the transfer unit from which the substrate is separated to the loading unit by using a second conveyer unit installed to pass through the chamber, wherein each of the plurality of organic layer deposition assemblies includes: a plurality of deposition sources, each of the plurality of deposition sources being configured to discharge a corresponding one of a plurality of deposition materials; and a deposition source nozzle unit at a side of each of the deposition sources, and including one or more deposition source

nozzles, the organic layer deposition assemblies include a plurality of common layer deposition assemblies for forming a common layer and a plurality of pattern layer deposition assemblies for forming a pattern layer, each of the pattern layer deposition assemblies further includes a correction slit sheet including a plurality of correction slits, the correction slits of the pattern layer deposition assemblies are offset with respect to each other along a first direction in which the substrate is transported, and the substrate is spaced apart from the organic layer deposition apparatus so as to be relatively movable with respect to the organic layer deposition apparatus, and the deposition materials discharged from the deposition sources pass through respective said correction slit sheets and are deposited in a pattern on the substrate.

[0029] The chamber may accommodate the organic layer deposition assemblies with which deposition is continuously performed on the substrate.

[0030] The transfer unit may circulate between the first conveyer unit and the second conveyer unit.

[0031] The first conveyer unit and the second conveyer unit may be arranged in parallel and one on top of the other.

[0032] A length of patterning slit sheets of the organic layer deposition assemblies in at least one of the first direction or a second direction perpendicular to the first direction may be less than that of the substrate.

[0033] According to another embodiment of the present invention, an organic light-emitting display apparatus includes: a substrate; a plurality of thin film transistors on the substrate and each including a semiconductor active layer, a gate electrode insulated from the semiconductor active layer, and source and drain electrodes each contacting the semiconductor active layer; a plurality of pixel electrodes respectively on the thin film transistors; a plurality of organic layers respectively on the plurality of pixel electrodes; and a counter electrode on the plurality of organic layers, wherein a length of a slanted side between a top side and a bottom side of at least one of the organic layers on the substrate farther from a center of a deposition region is greater than lengths of slanted sides of other ones of the organic layers formed closer to the center of the deposition region, and the at least one of the organic layers on the substrate is a linearly-patterned organic layer formed using the organic layer deposition apparatus described above.

[0034] The substrate may have a size of 40 inches or more.

[0035] Each of the organic layers may include at least an emission layer.

[0036] The organic layers may have a non-uniform thickness.

[0037] Among the organic layers located in the deposition region, an organic layer located farther from the center of the deposition region may have a narrower interval between facing sides of a pattern of the organic layer extending in the first direction than the organic layers located closer to the center.

[0038] The farther the organic layer in the deposition region is from the center of the deposition region, the narrower an overlapping region of two sides of the organic layer may be.

[0039] Slanted sides between top and bottom side of the organic layer disposed at the center of the deposition region may have substantially equal lengths.

[0040] The organic layers in the deposition region may be symmetrically arranged about the center of the deposition region.

[0041] According to another embodiment of the present invention, an organic layer deposition apparatus is provided.

The organic layer deposition apparatus includes: a conveyer unit including a transfer unit for attaching a substrate and configured to move along with the substrate, a first conveyer unit for moving in a first direction the transfer unit on which the substrate is attached, and a second conveyer unit for moving in a direction opposite to the first direction the transfer unit from which the substrate is separated after deposition has been completed; a loading unit for attaching the substrate to the transfer unit; a deposition unit including a chamber maintained in a vacuum state and a plurality of organic layer deposition assemblies for depositing organic layers on the substrate attached to the transfer unit transferred from the loading unit; and an unloading unit for separating, from the transfer unit, the substrate on which the deposition has been completed while passing through the deposition unit. The transfer unit is configured to move between the first conveyer unit and the second conveyer unit, and the substrate attached to the transfer unit is configured to be spaced from the plurality of organic layer deposition assemblies while being transferred by the first conveyer unit. Each of the plurality of organic layer deposition assemblies includes: a plurality of deposition sources, each of the plurality of deposition sources being configured to discharge a corresponding one of a plurality of deposition materials; a deposition source nozzle unit at a side of each of the plurality of deposition sources and including one or more deposition source nozzles; a patterning slit sheet facing the deposition source nozzle unit and including one or more patterning slits; and a modification shutter located between the plurality of deposition sources and the patterning slit sheet and including an opening that is configured to allow the deposition material to pass-through towards the patterning slit sheet. The openings of adjacent ones of the modification shutters are offset from each other along a second direction perpendicular to the first direction, and the deposition materials discharged from the plurality of deposition sources pass through the patterning slit sheet and are deposited on the substrate in patterns.

[0042] The opening of the modification shutter may be elongated in the first direction.

[0043] Locations of the openings of the modification shutters may be different from each other.

[0044] The patterns deposited on the substrate through the openings may not overlap each other.

[0045] In one embodiment, when thicknesses of the plurality of organic layers are measured, a modifying substrate is transferred through the organic layer deposition apparatus, and the modification shutter is located between the plurality of deposition sources and the patterning slit sheet such that the deposition materials are deposited on the modifying substrate by passing through the opening of the modification shutter.

[0046] The deposition unit may include  $m$  organic layer deposition assemblies, each of the  $m$  organic layer deposition assemblies may include  $n$  deposition sources, and each of the  $m$  organic layer deposition assemblies may include one modification shutter, wherein  $m$  and  $n$  are natural numbers.

[0047] In one embodiment, when the thicknesses of the plurality of organic layers are measured, the  $(n-1)$ th deposition source is activated, and the modifying substrate is transferred in the first direction and the deposition material is deposited on the modifying substrate from the activated  $(n-1)$ th deposition source while the deposition materials of the deposition sources other than the  $(n-1)$ th deposition source are blocked from reaching the modifying substrate, and after

the modifying substrate is out of the deposition unit, the  $(n)$ th deposition source is activated, and the modifying substrate is transferred in the first direction and the deposition material is deposited on the modifying substrate from the activated  $(n)$ th deposition source while the deposition materials of the deposition sources other than the  $(n)$ th deposition source are blocked from reaching the modifying substrate.

[0048] Each of the plurality of organic layer deposition assemblies may include a same number of the plurality of deposition sources, and a number of modifying substrates used to measure the thicknesses of the organic layers and the number of the plurality of deposition sources may be same.

[0049] The first conveyer unit and the second conveyer unit may be configured to pass through the deposition unit.

[0050] The first conveyer unit and the second conveyer unit may be arranged parallel to each other one on top of the other.

[0051] The first conveyer unit may be configured to sequentially transfer the transfer unit into the loading unit, the deposition unit, and the unloading unit.

[0052] The second conveyer unit may be configured to sequentially transport the transfer unit into the unloading unit, the deposition unit, and the loading unit.

[0053] The patterning slit sheet of each of the plurality of organic layer deposition assemblies may be smaller than the substrate in at least one of the first direction or the second direction perpendicular to the first direction.

[0054] The deposition source nozzle unit may include a plurality of deposition source nozzles arranged along the second direction perpendicular to the first direction, the patterning slit sheet may include a plurality of patterning slits arranged along the second direction, and the organic layer deposition apparatus may further include a shielding plate assembly arranged along the second direction between the deposition source nozzle unit and the patterning slit sheet and including a plurality of shielding plates for defining a space between the deposition source nozzle unit and the patterning slit sheet to a plurality of deposition spaces.

[0055] Each of the plurality of shielding plates may extend along the first direction.

[0056] The shielding plate assembly may include a first shielding plate assembly including a plurality of first shielding plates and a second shielding plate assembly including a plurality of second shielding plates.

[0057] Each of the plurality of first shielding plates and each of the plurality of second shielding plates may be arranged along the second direction such as to define the space between the deposition source nozzle unit and the patterning slit sheet to the plurality of deposition spaces.

[0058] The deposition source nozzle unit may include a plurality of deposition source nozzles arranged along the first direction, and the patterning slit sheet may have a plurality of patterning slits arranged along the second direction perpendicular to the first direction.

[0059] The plurality of deposition sources, the deposition source nozzle unit, and the patterning slit sheet may be integrally formed by being connected to each other via a connecting member.

[0060] The connecting member may be configured to guide a flow path of the deposition material.

[0061] The connecting member may be configured to seal a space between the deposition source nozzle and the patterning slit sheet.

[0062] In another embodiment according to the present invention, a method of manufacturing an organic light-emit-

ting display apparatus by using an organic layer deposition apparatus for forming an organic layer on a substrate is provided. The method includes: attaching the substrate to a transfer unit in a loading unit; transporting, into a chamber, the transfer unit to which the substrate is attached, by using a first conveyer unit passing through the chamber; forming organic layers by depositing deposition materials discharged from a plurality of organic layer deposition assemblies on the substrate while the substrate is spaced apart from and moved relative to the organic layer deposition assemblies in the chamber; separating the substrate on which the depositing has been completed from the transfer unit in an unloading unit; and transporting the transfer unit from which the substrate is separated to the loading unit by using a second conveyer unit passing through the chamber. Each of the organic layer deposition assemblies includes: a plurality of deposition sources, each of the deposition sources being configured to discharge a corresponding one of the deposition materials; a deposition source nozzle unit at a side of each of the plurality of deposition sources and comprising one or more deposition source nozzles; a patterning slit sheet facing the deposition source nozzle unit and comprising one or more patterning slits; and a modification shutter located between the plurality of deposition sources and the patterning slit sheet and having an opening that is configured to allow the corresponding ones of the deposition materials from the deposition sources to pass through towards the patterning slit sheet. The openings of adjacent ones of the modification shutters are offset from each other along a second direction perpendicular to a first direction in which the substrate is transported, and the deposition materials discharged from the plurality of deposition sources pass through the patterning slit sheet and are deposited on the substrate in patterns.

**[0063]** The chamber may include a plurality of the organic layer deposition assemblies, and wherein deposition may be sequentially performed on the substrate by using each of the plurality of the organic layer deposition assemblies.

**[0064]** The transfer unit may be moved between the first conveyer unit and the second conveyer unit.

**[0065]** The first conveyer unit and the second conveyer unit may be arranged in parallel to each other above and below.

**[0066]** The patterning slit sheet of the organic layer deposition assembly may be formed smaller than the substrate in at least one of a first direction or the second direction perpendicular to the first direction.

**[0067]** In another embodiment according to the present invention, an organic light-emitting display apparatus is provided. The organic light-emitting display apparatus includes: a substrate; at least one thin film transistor on the substrate and including a semiconductor active layer, a gate electrode insulated from the semiconductor active layer, and source and drain electrodes each contacting the semiconductor active layer; a plurality of pixel electrodes on the at least one thin film transistor; a plurality of organic layers on the plurality of the pixel electrodes; and a counter electrode located on the plurality of organic layers. A length of a slanted side between top and bottom sides of at least one of the plurality of organic layers on the substrate farther from a center of a deposition region is larger than lengths of slanted sides between respective top and bottom sides of other ones of the plurality of organic layers formed closer to the center of the deposition region, and the at least one of the plurality of organic layers on the substrate is a linearly-patterned organic layer formed using an organic layer deposition apparatus described above.

**[0068]** The substrate may have a size of 40 inches or more.

**[0069]** The plurality of organic layers may include at least an emission layer.

**[0070]** The plurality of organic layers may have a non-uniform thickness.

**[0071]** In each of the organic layers formed farther from the center of the deposition region, the slanted side farther from the center of the deposition region may be larger than the other slanted side.

**[0072]** The further one of the plurality of organic layers in the deposition region is from the center of the deposition region, the narrower an overlapped region of two sides of the one of the plurality of organic layers may be formed.

**[0073]** The slanted sides of the organic layer disposed at the center of the deposition region may have substantially the same length.

**[0074]** The plurality of organic layers in the deposition region may be symmetrically arranged about the center of the deposition region.

**[0075]** According to another embodiment of the present invention, there is provided an apparatus for organic layer deposition including a conveyer unit including a transfer unit on which a substrate is fixed to move therewith; a first conveyer unit, which moves the transfer unit on which the substrate is fixed in a first direction; and a second conveyer unit, which moves the transfer unit from which the substrate is detached after deposition in a direction opposite to the first direction; and a deposition unit including a chamber maintained at a vacuum; and one or more organic layer deposition assemblies which deposit organic material layers on the substrate fixed to the transfer unit, wherein the organic layer deposition assembly includes a deposition source, which emits a deposition material; a deposition source nozzle unit, which is arranged on one side of the deposition source, the deposition source nozzle unit including a plurality of deposition source nozzles; a patterning slit sheet, which is arranged to face the deposition source nozzle unit, the patterning slit sheet including a plurality of patterning slits arranged in a direction; and a first tooling shutter, which is arranged between the deposition source and the patterning slit sheet to cover at least a portion of the substrate, the first tooling shutter including one or more tooling slits formed in the first direction, wherein the transfer unit is able to move back and forth between the first conveyer unit and the second conveyer unit, and the substrate that is fixed to the transfer unit is a set distance apart from the organic layer deposition assemblies while being transported by the first conveyer unit.

**[0076]** The first tooling shutter may be arranged at each of the plurality of organic layer deposition assemblies, and the tooling slits formed in each of the first tooling shutters may be formed to be offset to one another.

**[0077]** The first tooling shutter may be arranged at the organic layer deposition assembly for depositing a common layer, among the plurality of organic layer deposition assemblies.

**[0078]** In one embodiment, the first tooling shutter is arranged to cover at least a portion of the substrate only when the substrate for tooling is transported in the deposition unit.

**[0079]** In the organic layer deposition assembly for depositing a pattern layer according to one embodiment, among the plurality of organic layer deposition assemblies, a second tooling shutter, which is arranged between the deposition source and the patterning slit sheet to cover at least a portion

of the substrate and including tooling slits at two opposite ends along the first direction, is further formed.

**[0080]** A width of the tooling slit of the second tooling shutter may be greater than a width of the patterning slit of the patterning slit sheet.

**[0081]** In one embodiment, the first conveyer unit and the second conveyer unit are arranged to pass through the deposition unit.

**[0082]** In one embodiment, the first conveyer unit and the second conveyer unit are arranged next to each other in a vertical direction.

**[0083]** In one embodiment, the apparatus further includes a loading unit in which the substrate is fixed to the transfer unit; and an unloading unit in which the substrate is detached from the transfer unit after the substrate passes through the deposition unit and deposition thereon is completed.

**[0084]** In one embodiment, the first conveyer unit moves the transfer unit to the loading unit, the deposition unit, and the unloading unit in the order stated.

**[0085]** In one embodiment, the second conveyer unit moves the transfer unit to the unloading unit, the deposition unit, and the loading unit in the order stated.

**[0086]** In the organic layer deposition assemblies according to one embodiment, the deposition material emitted by the deposition source passes through the patterning slit sheet and is deposited to form a pattern on the substrate.

**[0087]** In one embodiment, the patterning slit sheet of the organic layer deposition assemblies is smaller than the substrate.

**[0088]** In one embodiment, a magnetic rail is formed in a surface of the transfer unit, a plurality of coils are formed at each of the first conveyer unit and the second conveyer unit, and the magnetic rail and the coils are combined with each other and constitute a driving unit which generates driving power for moving the transfer unit.

**[0089]** In one embodiment, the plurality of deposition source nozzles are formed at the deposition source nozzle unit in the first direction, and the plurality of patterning slits are formed at the patterning slit sheet in the first direction. The apparatus further includes a shielding plate assembly, which includes a plurality of shielding plates that are arranged between the deposition source nozzle unit and the patterning slit sheet in the first direction and defines the space between the deposition source nozzle unit and the patterning slit sheet into a plurality of deposition spaces.

**[0090]** In one embodiment, each of the plurality of shielding plates extends in a second direction substantially perpendicular to the first direction.

**[0091]** In one embodiment, the shielding plate assembly includes a first shielding plate assembly including a plurality of first shielding plates; and a second shielding plate assembly including a plurality of second shielding plates.

**[0092]** In one embodiment, the plurality of deposition source nozzles are formed at the deposition source nozzle unit in the first direction, and the plurality of patterning slits are formed at the patterning slit sheet in a second direction perpendicular to the first direction.

**[0093]** In one embodiment, the deposition source, the deposition source nozzle unit, and the patterning slit sheet are connected to one another via a connecting member and are formed as a single body.

**[0094]** In one embodiment, the connecting member guides a path in which the deposition material moves.

**[0095]** In one embodiment, the connecting member is formed to seal a space formed by the deposition source, the deposition source nozzle unit, and the patterning slit from outside.

**[0096]** According to another embodiment of the present invention, there is provided a method of using the apparatus for organic layer deposition for forming an organic material layer on a substrate, the method including an operation in which, while a substrate is fixed to a transfer unit, the transfer unit is transported into a chamber by a first conveyer unit that is configured to pass through the chamber; an operation in which, when a plurality of organic layer deposition assemblies are a set or predetermined distance apart from the substrate, the substrate moves relative to the organic layer deposition assemblies and organic material layers are formed as deposition materials emitted by the organic layer deposition assemblies are deposited on the substrate; and an operation in which the transfer unit from which the substrate is detached is transported back by a second conveyer unit that is configured to pass through the chamber, wherein the operation in which the organic material layer is formed includes an operation in which, while a substrate for tooling is being transported in the organic layer deposition assemblies, the deposition material is deposited onto the tooling substrate by a first tooling shutter in which one or more tooling slits are formed.

**[0097]** In one embodiment, the first tooling shutter is arranged in each of the plurality of organic layer deposition assemblies, and the tooling slits formed in the first tooling shutters are formed to be somewhat offset to one another.

**[0098]** In one embodiment, the first tooling shutter is arranged in an organic layer deposition assembly for depositing a common layer, among the plurality of organic layer deposition assemblies.

**[0099]** In one embodiment, the first tooling shutter is arranged to cover at least a portion of the substrate only while the tooling substrate is being transported in the organic layer deposition assemblies.

**[0100]** In one embodiment, the method further includes an operation in which the substrate is fixed to the transfer unit at the loading unit before the transfer unit is transported by the first conveyer unit; and an operation in which the substrate, to which deposition is completed, is detached from the transfer unit at the unloading unit before the transfer unit is transported back by the second conveyer unit.

**[0101]** In one embodiment, the transfer unit moves back and forth between the first conveyer unit and the second conveyer unit.

**[0102]** In one embodiment, the first conveyer unit and the second conveyer unit are arranged next to each other in a vertical direction.

**[0103]** In one embodiment, each of the organic layer deposition assemblies includes a deposition source, which emits a deposition material; a deposition source nozzle unit, which is arranged at one side of the deposition source, the deposition source nozzle unit including a plurality of deposition source nozzles; a patterning slit sheet, which is arranged to face the deposition source nozzle unit, the patterning slit sheet including a plurality of patterning slits arranged in a direction, and the deposition material emitted by the deposition source passes through the patterning slit sheet and is deposited to form a pattern on the substrate.

**[0104]** In an organic layer deposition assembly for depositing a pattern layer among the plurality of organic layer deposition assemblies according to one embodiment, a sec-

ond tooling shutter, which is arranged between the deposition nozzle and the patterning slit sheet to cover at least a portion of the substrate and includes tooling slits formed at two opposite ends, is formed.

[0105] In one embodiment, a width of the tooling slit of the second tooling shutter is greater than a width of the patterning slit of the patterning slit sheet.

[0106] In one embodiment, the patterning slit sheet of the organic layer deposition assembly is formed smaller than the substrate in at least any one of the first direction and the second direction perpendicular to the first direction.

[0107] According to another embodiment of the present invention, there is provided an organic light-emitting display device including a substrate; at least one thin film transistor that is disposed on the substrate and includes a semiconductor active layer, a gate electrode insulated from the semiconductor active layer, and source and drain electrodes each contacting the semiconductor active layer; a plurality of pixel electrodes disposed on the at least one thin film transistor; a plurality of organic layers disposed on the plurality of the pixel electrodes; and a counter electrode disposed on the plurality of organic layers, wherein a length of a slanted side between top and bottom sides of at least one of the plurality of organic layers formed on the substrate farther from a center of a deposition region is larger than slanted sides between respective top and bottom sides of the other organic layers formed closer to the center of the deposition region, wherein the at least one of the plurality of organic layers formed on the substrate is a linearly-patterned organic layer formed using the organic layer deposition apparatus above.

[0108] In one embodiment, the substrate has a size of 40 inches or more.

[0109] In one embodiment, the plurality of organic layers include at least an emission layer.

[0110] In one embodiment, the plurality of organic layers have a non-uniform thickness.

[0111] According to one embodiment, in each of the organic layers formed farther from the center of the deposition region, the slanted side farther from the center of the deposition region is larger than the other slanted sides.

[0112] In one embodiment, the further one of the plurality of organic layers formed in the deposition region is from the center of the deposition region, the narrower an overlapped region of two sides of the one of the plurality of organic layers is formed.

[0113] In one embodiment, hypotenuses of the organic layer disposed at the center of the deposition region have substantially the same length.

[0114] In one embodiment, the plurality of organic layers disposed in the deposition region are symmetrically arranged about the center of the deposition region.

#### BRIEF DESCRIPTION OF THE DRAWINGS

[0115] The above and other features and aspects of the present invention will become more apparent by describing in detail embodiments thereof with reference to the attached drawings in which:

[0116] FIG. 1 is a schematic plan view illustrating a structure of an organic layer deposition apparatus according to an embodiment of the present invention;

[0117] FIG. 2 is a schematic side view of a deposition unit of the organic layer deposition apparatus of FIG. 1, according to an embodiment of the present invention;

[0118] FIG. 3 is a schematic perspective view of the deposition unit of the organic layer deposition apparatus of FIG. 1, according to an embodiment of the present invention;

[0119] FIG. 4 is a schematic cross-sectional view of the deposition unit of FIG. 3, according to an embodiment of the present invention;

[0120] FIG. 5 is a perspective view of a deposition source of the deposition unit of FIG. 3, according to an embodiment of the present invention;

[0121] FIG. 6 is a perspective view of a deposition source of the deposition unit of FIG. 3, according to another embodiment of the present invention;

[0122] FIG. 7 is a schematic cross-sectional view of a first conveyer unit and a transfer unit of the deposition unit of FIG. 3 according to an embodiment of the present invention;

[0123] FIG. 8 is a schematic perspective view of a tooling shutter while the deposition unit of FIG. 3 is depositing an organic material layer according to an embodiment of the present invention;

[0124] FIG. 9 is a schematic perspective view of a tooling shutter while the deposition unit of FIG. 3 in a tooling operation according to an embodiment of the present invention;

[0125] FIG. 10 is a schematic view showing that, during the tooling operation of FIG. 9, an organic material layer is formed as a substrate passes through a first organic layer deposition assembly according to an embodiment of the present invention;

[0126] FIG. 11 is a schematic view showing that, during the tooling operation of FIG. 9, an organic material layer is formed as a substrate passes through a second organic layer deposition assembly according to an embodiment of the present invention;

[0127] FIG. 12 is a schematic view showing that, during the tooling operation of FIG. 9, an organic material layer is formed as a substrate passes through a third organic layer deposition assembly according to an embodiment of the present invention;

[0128] FIG. 13 is a schematic perspective view of deposition assemblies including deposition sources, according to an embodiment of the present invention;

[0129] FIG. 14 is a schematic plan view of examples of correction slit sheets;

[0130] FIG. 15 is a schematic plan view of other examples of correction slit sheets;

[0131] FIG. 16 is a schematic perspective view of deposition assemblies each including a deposition unit, according to an embodiment of the present invention;

[0132] FIGS. 17 and 18 are schematic plan views illustrating operations of modification shutters, according to an embodiment of the present invention;

[0133] FIG. 19 is a schematic view of an organic layer deposition assembly according to another embodiment of the present invention;

[0134] FIG. 20 is a schematic side-sectional view of the organic layer deposition assembly of FIG. 19;

[0135] FIG. 21 is a schematic plan sectional view of the organic layer deposition assembly of FIG. 19;

[0136] FIG. 22 is a schematic view of an organic layer deposition assembly according to another embodiment of the present invention;

[0137] FIG. 23 is a schematic view of an organic layer deposition assembly according to another embodiment of the present invention;

[0138] FIG. 24 is a schematic view illustrating equidistant patterning slits of a patterning slit sheet of the organic layer deposition apparatus of FIG. 3;

[0139] FIG. 25 is a schematic view of organic layers that are formed by using the patterning slit sheet of FIG. 24; and

[0140] FIG. 26 is a cross-sectional view of an active matrix-type organic light-emitting display apparatus that is manufactured using an organic layer deposition apparatus according to an embodiment of the present invention.

#### DETAILED DESCRIPTION

[0141] As used herein, the term “and/or” includes any and all combinations of one or more of the associated listed items. Expressions such as “at least one of,” when preceding a list of elements, modify the entire list of elements and do not modify the individual elements of the list.

[0142] Reference will now be made in detail to embodiments of the present invention, examples of which are illustrated in the accompanying drawings, wherein like reference numerals refer to like elements throughout. The embodiments are described below in order to explain aspects of the present invention by referring to the figures.

[0143] FIG. 1 is a schematic plan view illustrating a structure of an organic layer deposition apparatus 1 according to an embodiment of the present invention. FIG. 2 is a schematic side view of a deposition unit 100 of the organic layer deposition apparatus 1 of FIG. 1, according to an embodiment of the present invention.

[0144] Referring to FIGS. 1 and 2, the organic layer deposition apparatus 1 includes the deposition unit 100, a loading unit 200, an unloading unit 300, and a conveyer unit 400 (refer to FIGS. 3 and 4).

[0145] The loading unit 200 may include a first rack 212, a transport chamber 214, a first inversion chamber 218, and a buffer chamber 219.

[0146] A plurality of substrates 2 (for example, one substrate 2 is shown in FIGS. 3 and 4) onto which a deposition material has not yet been applied are stacked up on the first rack 212. A transport robot included in the transport chamber 214 picks up one of the substrates 2 from the first rack 212, places the substrate 2 on a transfer unit 430 transferred by a second conveyer unit 420, and moves the transfer unit 430, on which the substrate 2 is placed, into the first inversion chamber 218.

[0147] The first inversion chamber 218 is located adjacent to the transport chamber 214. The first inversion chamber 218 includes a first inversion robot that inverts the transfer unit 430 and then loads it on a first conveyer unit 410 of the deposition unit 100.

[0148] Referring to FIG. 1, the transport robot of the transport chamber 214 places one of the substrates 2 on a top surface of the transfer unit 430, and the transfer unit 430, on which the substrate 2 is placed, is then transferred into the first inversion chamber 218. The first inversion robot of the first inversion chamber 218 inverts the transfer unit 430 so that the substrate 2 is turned upside down in the deposition unit 100.

[0149] The unloading unit 300 is configured to operate in an opposite manner to the loading unit 200 described above. For example, a second inversion robot in a second inversion chamber 328 inverts the substrate 2 and the transfer unit 430, which have passed through the deposition unit 100, and then moves the substrate 2 and the transfer unit 430 to an ejection chamber 324. Then, an ejection robot takes the substrate 2 and the transfer unit 430 out of the ejection chamber 324, sepa-

rates the substrate 2 from the transfer unit 430, and then loads the substrate 2 on a second rack 322. The transfer unit 430, from which the substrate 2 is separated, is returned to the loading unit 200 via the second conveyer unit 420.

[0150] However, the present invention is not limited to the above example. For example, when placing the substrate 2 on the transfer unit 430, the substrate 2 may be fixed (or attached) onto a bottom surface of the transfer unit 430 and then moved into the deposition unit 100. In such an embodiment, for example, the first inversion robot of the first inversion chamber 218 and the second inversion robot of the second inversion chamber 328 may be omitted.

[0151] The deposition unit 100 may include at least one chamber for deposition. In one embodiment, as illustrated in FIGS. 1 and 2, the deposition unit 100 includes a chamber 101 in which a plurality of organic layer deposition assemblies (100-1), (100-2) through (100-*n*) may be located. Referring to FIG. 1, 11 organic layer deposition assemblies, i.e., an organic layer deposition assembly (100-1), an organic layer deposition assembly (100-2), through an organic layer deposition assembly (100-11), are located in the chamber 101, but the number of organic layer deposition assemblies may vary with a desired deposition material and deposition conditions. The chamber 101 is maintained in vacuum during the deposition process. According to an embodiment of the present invention, the organic layer deposition assemblies (For example, see 100-1, 100-2, through 100-11 of FIG. 7) may include a plurality of common layer deposition assemblies (100-1, 100-2, 100-3, 100-4, 100-10, and 100-11 of FIG. 7) for forming common layers and a plurality of pattern layer deposition assemblies (100-5, 100-6, 100-7, 100-8, and 100-9 of FIG. 7) for forming the pattern layers. This will be described later.

[0152] In the embodiment illustrated in FIG. 1, the transfer unit 430 with the substrate 2 fixed thereon (or attached thereto) may be moved at least to the deposition unit 100 or may be moved sequentially to the loading unit 200, the deposition unit 100, and the unloading unit 300, by the first conveyer unit 410, and the transfer unit 430 from which the substrate 2 is separated in the unloading unit 300 may be moved back to the loading unit 200 by the second conveyer unit 420.

[0153] The first conveyer unit 410 passes through the chamber 101 when passing through the deposition unit 100, and the second conveyer unit 420 conveys (or transports) the transfer unit 430 from which the substrate 2 is separated.

[0154] In the present embodiment, the organic layer deposition apparatus 1 is configured such that the first conveyer unit 410 and the second conveyer unit 420 are respectively disposed above and below so that after the substrate 2 is separated from the transfer unit 430, on which deposition has been completed while passing through the first conveyer unit 410, the transfer unit 430 is returned to the loading unit 200 via the second conveyer unit 420 formed below the first conveyer unit 410, and thus, the organic layer deposition apparatus 1 may have an improved space utilization efficiency. In other words, the first and second conveyer units 410 and 420 are arranged in parallel, one on top of the other.

[0155] In an embodiment, the deposition unit 100 illustrated in FIG. 1 may further include a deposition source replacement unit 190 located at a side of each organic layer deposition assembly 100-*n*. Although not particularly illustrated in the drawings, the deposition source replacement unit 190 may be formed as a cassette-type that may be drawn to the

outside from each organic layer deposition assembly. Thus, a deposition source **110** (refer to FIG. 3) of the organic layer deposition assembly **100-1** may be replaced with relative ease.

[0156] FIG. 1 illustrates the organic layer deposition apparatus **1** in which two sets of structures each including the loading unit **200**, the deposition unit **100**, the unloading unit **300**, and the conveyer unit **400** are arranged in parallel. That is, it is seen that two organic layer deposition apparatuses **1** are respectively arranged side-by-side (above and below in FIG. 1). In such an embodiment, a patterning slit sheet replacement unit **500** may be further located between the two organic layer deposition apparatuses **1**. That is, due to this configuration of structures, the two organic layer deposition apparatuses **1** share the patterning slit sheet replacement unit **500**, resulting in improved space utilization efficiency, as compared to a case where each organic layer deposition apparatus **1** includes a patterning slit sheet replacement unit **500**.

[0157] FIG. 3 is a schematic perspective view of the deposition unit **100** of the organic layer deposition apparatus **1** of FIG. 1, according to an embodiment of the present invention. FIG. 4 is a schematic cross-sectional view of the deposition unit **100** of FIG. 3, according to an embodiment of the present invention.

[0158] Referring to FIGS. 3 and 4, the deposition unit **100** of the organic layer deposition apparatus **1** includes at least one organic layer deposition assembly **100-1** and the conveyer unit **400**.

[0159] Hereinafter, an overall structure of the deposition unit **100** will be described.

[0160] The chamber **101** may be formed as a hollow box type and may include the at least one organic layer deposition assembly **100-1** and the conveyer unit **400**. A foot **102** is formed so as to fix the deposition unit **100** on the ground, a lower housing **103** is located on the foot **102**, and an upper housing **104** is located on the lower housing **103**. The chamber **101** accommodates both the lower housing **103** and the upper housing **104**. In this regard, a connection part of the lower housing **103** and the chamber **101** is sealed so that the inside of the chamber **101** is completely isolated from the outside. Due to the structure in which the lower housing **103** and the upper housing **104** are located on the foot **102** fixed on the ground, the lower housing **103** and the upper housing **104** may be maintained in a fixed position even though the chamber **101** is repeatedly contracted and expanded. Thus, the lower housing **103** and the upper housing **104** may serve as a reference frame in the deposition unit **100**.

[0161] The upper housing **104** includes the organic layer deposition assembly **100-1** and the first conveyer unit **410** of the conveyer unit **400**, and the lower housing **103** includes the second conveyer unit **420** of the conveyer unit **400**. While the transfer unit **430** is cyclically moving between the first conveyer unit **410** and the second conveyer unit **420**, a deposition process is continuously performed.

[0162] Hereinafter, constituents of the organic layer deposition assembly **100-1** are described in detail.

[0163] The organic layer deposition assembly **100-1** includes the deposition source **110**, a deposition source nozzle unit **120**, a patterning slit sheet **130**, a shielding member **140**, a first stage **150**, a second stage **160**, a camera(s) **170**, and a sensor(s) **180**. In this regard, all the elements illustrated in FIGS. 3 and 4 may be arranged in the chamber **101** maintained in an appropriate vacuum state. This structure is used to achieve the linearity of a deposition material.

[0164] For example, in order to deposit a deposition material **115** that has been discharged from the deposition source **110** and passed through the deposition source nozzle unit **120** and the patterning slit sheet **130**, onto the substrate **2** in a desired pattern, it is desirable to maintain the vacuum state of the chamber (not shown) at high levels as those used in a fine metal mask (FMM) deposition method. In addition, the temperature of the patterning slit sheet **130** should be sufficiently lower than that of the deposition source **110** because thermal expansion of the patterning slit sheet **130** is reduced or minimized when the temperature of the patterning slit sheet **130** is sufficiently low.

[0165] The substrate **2**, on which the deposition material **115** is to be deposited, is arranged in the chamber **101**. The substrate **2** may be a substrate for a flat panel display apparatus (device). For example, a large substrate, such as a mother glass, for manufacturing a plurality of flat panel displays, may be used as the substrate **2**.

[0166] According to the present embodiment, the deposition process may be performed by moving the substrate **2** relative to the organic layer deposition assembly **100-1**.

[0167] In a conventional deposition method using an FMM, the size of the FMM is the same as that of a substrate. Thus, as the size of the substrate increases, the size of the FMM also increases. Due to these problems, it is difficult to fabricate the FMM and to align the FMM in a precise pattern by elongating the FMM.

[0168] To address these problems, in the organic layer deposition assembly **100-1** according to the present embodiment, deposition may be performed while the organic layer deposition assembly **100-1** and the substrate **2** are moved relative to each other. In other words, deposition may be continuously performed while the substrate **2**, which faces the organic layer deposition assembly **100-1**, is moved in a Y-axis direction. That is, deposition is performed in a scanning manner while the substrate **2** is moved in a direction of arrow A illustrated in FIG. 3. Although the substrate **2** is illustrated as moving in the Y-axis direction in the chamber **101** in FIG. 3 when deposition is performed, the present invention is not limited thereto. For example, deposition may be performed while the substrate **2** is fixed and the organic layer deposition assembly **100-1** is moved in the Y-axis direction.

[0169] Thus, in the organic layer deposition assembly **100-1**, the patterning slit sheet **130** may be smaller (e.g., much smaller) than an FMM used in a conventional deposition method. In other words, in the organic layer deposition assembly **100-1**, deposition is continuously performed, i.e., in a scanning manner while the substrate **2** is moved in the Y-axis direction. Thus, at least one of the lengths of the patterning slit sheet **130** in X-axis and Y-axis directions may be less (e.g., much less) than a length of the substrate **2** in the same direction. Because the patterning slit sheet **130** may be formed smaller (e.g., much smaller) than the FMM used in a conventional deposition method, it is relatively easy to manufacture the patterning slit sheet **130**. That is, the small patterning slit sheet **130** is more suitable in view of the manufacturing processes, including etching, and precise elongation, welding, transferring, and washing processes which are performed after the etching, than the FMM used in a conventional deposition method. In addition, this is more suitable for manufacturing a relatively large display apparatus (device).

[0170] In order to perform deposition while the organic layer deposition assembly **100-1** and the substrate **2** are

moved relative to each other as described above, the organic layer deposition assembly **100-1** and the substrate **2** may be spaced apart from each other by a certain distance (e.g., a gap). This is described below in more detail.

[0171] The deposition source **110** that contains and heats the deposition material **115** is located facing the substrate **2** in the chamber **101**. As the deposition material **115** contained in the deposition source **110** is vaporized, deposition is performed on the substrate **2**.

[0172] The deposition source **110** includes a crucible **111** that is filled with the deposition material **115** and a heater **112** that heats the crucible **111** so as to vaporize the deposition material **115** toward a side of the crucible **111**, in particular, toward the deposition source nozzle unit **120**.

[0173] The deposition source nozzle unit **120**, in one embodiment, is located at a side of the deposition source **110**, for example, a side of the deposition source **110** toward (or facing) the substrate **2**. In this regard, the organic layer deposition assemblies according to the present embodiment may each include different deposition nozzles for performing deposition for forming common layers and pattern layers. That is, a deposition source nozzle unit **120** for forming pattern layers may include a plurality of deposition source nozzles **121** arranged along the Y-axis direction, that is, a scanning direction of the substrate **2**. Accordingly, along the X-axis direction, only one deposition source nozzle **121** is formed and thus shadows are substantially reduced. A source nozzle unit for forming common layers may include a plurality of deposition source nozzles **121** arranged along the X-axis direction, whereby a thickness uniformity of the common layers may be improved.

[0174] In one embodiment, the patterning slit sheet **130** may be located between the deposition source **110** and the substrate **2**. The patterning slit sheet **130** may further include a frame having a shape similar to a window frame. The patterning slit sheet **130** includes a plurality of patterning slits **131** arranged in the X-axis direction. The deposition material **115** that has been vaporized in the deposition source **110** passes through the deposition source nozzle unit **120** and the patterning slit sheet **130** and is then moved toward the substrate **2**. In this regard, the patterning slit sheet **130** may be formed using the same method as that used to form an FMM, in particular, a stripe-type mask. For example, the patterning slit sheet **130** may be formed by etching. In this regard, a total number of patterning slits **131** may be more than a total number of deposition source nozzles **121**.

[0175] In one embodiment, the deposition source **110** (and the deposition source nozzle unit **120** combined thereto) and the patterning slit sheet **130** may be spaced apart from each other by a certain distance (e.g., a gap).

[0176] As described above, deposition is performed while the organic layer deposition assembly **100-1** is moved relative to the substrate **2**. In order for the organic layer deposition assembly **100-1** to be moved relative to the substrate **2**, the patterning slit sheet **130** is spaced apart from the substrate **2** by a certain distance (e.g., a gap).

[0177] In a conventional deposition method using an FMM, deposition is typically performed with the FMM in close contact with a substrate in order to prevent formation of shadows on the substrate. However, when the FMM is formed in close contact with the substrate, defects due to the contact between the substrate and the FMM may occur. In addition, because it is difficult to move the mask with respect to the substrate, the mask and the substrate have the same size.

Accordingly, the mask becomes larger as the size of a display device increases. However, it is difficult to form a large mask.

[0178] To address these problems, in the organic layer deposition assembly **100-1** according to the present embodiment, the patterning slit sheet **130** is formed spaced apart by a certain distance (e.g., a gap) from the substrate **2** on which a deposition material is to be deposited.

[0179] According to the present embodiment, deposition may be performed while a mask formed smaller than a substrate is moved with respect to the substrate, and thus, it is relatively easy to manufacture the mask. In addition, defects due to contact between the substrate and the mask may be avoided. In addition, because it is unnecessary to closely contact the substrate with the mask during a deposition process, a manufacturing speed may be improved.

[0180] Hereinafter, particular dispositions of elements of the upper housing **104** will be described.

[0181] The deposition source **110** and the deposition source nozzle unit **120** are located at a bottom portion of the upper housing **104**. Accommodation portions **104-1** are respectively formed on both sides of the deposition unit **100** and the deposition source nozzle unit **120** to have a protruding shape. The first stage **150**, the second stage **160**, and the patterning slit sheet **130** are sequentially formed (or located) on the accommodation portions **104-1** in this order.

[0182] In this regard, the first stage **150** is formed to move in X-axis and Y-axis directions so that the first stage **150** aligns the patterning slit sheet **130** in the X-axis and Y-axis directions. That is, the first stage **150** includes a plurality of actuators so that the first stage **150** is moved in the X-axis and Y-axis directions with respect to the upper housing **104**.

[0183] The second stage **160** is formed to move in a Z-axis direction so as to align the patterning slit sheet **130** in the Z-axis direction. That is, the second stage **160** includes a plurality of actuators so as to move in the Z-axis direction with respect to the first stage **150**.

[0184] The patterning slit sheet **130** is located on the second stage **160**. The patterning slit sheet **130** is located on the first stage **150** and the second stage **160** so as to move in the X-axis, Y-axis, and Z-axis directions, and thus, an alignment, in particular, a real-time alignment, between the substrate **2** and the patterning slit sheet **130**, may be performed.

[0185] In addition, the upper housing **104**, the first stage **150**, and the second stage **160** may guide a flow path of the deposition material **115** such that the deposition material **115** discharged through the deposition source nozzles **121** is not dispersed outside the flow path. That is, the flow path of the deposition material **115** is sealed by the upper housing **104**, the first stage **150**, and the second stage **160**, and thus, the movement of the deposition material **115** in the X-axis and Y-axis directions may be thereby concurrently or simultaneously guided.

[0186] The shielding member **140** may be located between the patterning slit sheet **130** and the deposition source **110**. In particular, an anode or cathode pattern is formed on an edge portion of the substrate **2** and is used as a terminal for inspecting a product or in manufacturing a product. If an organic material is applied on this edge portion (i.e., the portion on which the anode or cathode pattern is formed) of the substrate **2**, the anode or the cathode cannot sufficiently perform its function. Thus, the edge portion of the substrate **2** is formed to be a non-film-forming region on which an organic material or the like is not applied. As described above, however, in the organic layer deposition apparatus, deposition is performed

in a scanning manner while the substrate **2** is moved relative to the organic layer deposition apparatus, and thus, it is not easy to prevent the organic material from being deposited on the non-film-forming region of the substrate **2**.

[0187] Therefore, to prevent the organic material from being deposited on the non-film-forming region of the substrate **2**, in the organic layer deposition apparatus, the shielding member **140** may be located at the edge portion of the substrate **2**. Although not particularly illustrated in FIGS. **3** and **4**, the shielding member **140** may include two adjacent plates.

[0188] When the substrate **2** does not pass through the organic layer deposition assembly **100-1**, the shielding member **140** screens the deposition source **110**, and thus, the deposition material **115** discharged from the deposition source **110** does not reach the patterning slit sheet **130**. When the substrate **2** enters into the organic layer deposition assembly **100-1** with the shielding member **140** screening the deposition source **110**, a front part of the shielding member **140**, which screens the deposition source **110**, moves along with the movement of the substrate **2**, and thus, the flow path of the deposition material **115** is opened and the deposition material **115** discharged from the deposition source **110** passes through the patterning slit sheet **130** and is deposited on the substrate **2**. Also, while the substrate **2** is passing through the organic layer deposition assembly **100-1**, a rear part of the shielding member **140** moves along with the movement of the substrate **2** to screen the deposition source **110** so that the flow path of the deposition material **115** is closed. Accordingly, the deposition material **115** discharged from the deposition source **110** does not reach the patterning slit sheet **130**.

[0189] As described above, the non-film-forming region of the substrate **2** is screened by the shielding member **140**, and thus, it is easy (or relatively easy) to prevent the organic material from being deposited on the non-film-forming region of the substrate **2** without using a separate structure.

[0190] Hereinafter, the conveyer unit **400** that conveys (or transports) the substrate **2**, on which the deposition material **115** is to be deposited, is described in more detail. Referring to FIGS. **3** and **4**, the conveyer unit **400** includes the first conveyer unit **410**, the second conveyer unit **420**, and the transfer unit **430**.

[0191] The first conveyer unit **410** conveys (or transports) in an in-line manner the transfer unit **430** and the substrate **2** attached to the transfer unit **430** so that an organic layer may be formed on the substrate **2** by the organic layer deposition assembly **100-1**, wherein the transfer unit **430** includes a carrier **431** and an electrostatic chuck **432** attached thereto. The first conveyer unit **410** includes a coil **411**, guide members **412**, upper magnetically suspended (e.g., magnetic levitation or magnetically levitating) bearings (not shown), side magnetically suspended (e.g., magnetic levitation or magnetically levitating) bearings (not shown), and gap sensors (not shown). In one embodiment, the magnetic levitation bearings and the gap sensors are mounted on the guide members **412**.

[0192] The second conveyer unit **420** returns to the loading unit **200** the transfer unit **430** from which the substrate **2** has been separated in the unloading unit **300** after one deposition cycle is completed while the transfer unit **430** is passing through the deposition unit **100**. The second conveyer unit **420** includes a coil **421**, roller guides **422**, and a charging track **423**.

[0193] The transfer unit **430** includes the carrier **431** that is conveyed (or transported) along the first conveyer unit **410** and the second conveyer unit **420** and the electrostatic chuck **432** that is combined on (or attached to) a surface of the carrier **431**. The substrate **2** is attached to the electrostatic chuck **432**.

[0194] Hereinafter, each element of the conveyer unit **400** will be described in more detail.

[0195] The carrier **431** of the transfer unit **430** will now be described in detail.

[0196] Referring to FIG. **7**, the carrier **431** includes a main body part **431a**, a magnetic rail (e.g., a linear motor system (LMS) magnet) **431b**, contactless power supply (CPS) modules **431c**, a power supply unit **431d**, and guide grooves. The carrier **431** may further include cam followers **431f**.

[0197] The main body part **431a** constitutes a base part of the carrier **431** and may be formed of a magnetic material, such as iron. In this regard, due to a repulsive force (and/or an attractive force) between the main body part **431a** of the carrier **431** and upper and side magnetically suspended bearings (e.g., magnetic levitation bearings) **413** and **414**, which are described below, the carrier **431** may be maintained spaced apart from the guide members **412** by a certain distance (e.g., a gap).

[0198] The guide grooves may be respectively formed at both sides of the main body part **431a** and each may accommodate a guide protrusion **412e** of the guide member **412**.

[0199] The magnetic rail **431b** may be formed along a center line of the main body part **431a** in a direction where the main body part **431a** proceeds. The magnetic rail **431b** of the main body part **431a**, and the coil **411**, which are described below in more detail, may be combined with each other to constitute a linear motor, and the carrier **431** may be conveyed (or transported) in an arrow A direction by the linear motor.

[0200] The CPS modules **431c** and the power supply unit **431d** may be respectively formed on both sides of the magnetic rail **431b** in the main body part **431a**. The power supply unit **431d** includes a battery (e.g., a rechargeable battery) that provides power so that the electrostatic chuck **432** can chuck (e.g., fix or hold) the substrate **2** and maintains operation. The CPS modules **431c** are wireless charging modules that charge the power supply unit **431d**. For example, the charging track **423** formed in the second conveyer unit **420**, which is described below, is connected to an inverter (not shown), and thus, when the carrier **431** is transferred into the second conveyer unit **420**, a magnetic field is formed between the charging track **423** and the CPS modules **431c** so as to supply power to the CPS modules **431c**. The power supplied to the CPS modules **431c** is used to charge the power supply unit **431d**.

[0201] The electrostatic chuck **432** may include an electrode embedded in a main body formed of ceramic, wherein the electrode is supplied with power. The substrate **2** is attached onto a surface of a main body of the electrostatic chuck **432** as a high voltage (e.g., a suitable voltage or a relatively high voltage) is applied to the electrode.

[0202] Hereinafter, the transfer unit **430** is described in detail.

[0203] The magnetic rail **431b** of the main body part **431a** and the coil **411** may be combined with each other to constitute an operation unit. In this regard, the operation unit may be a linear motor. The linear motor has a high degree (e.g., very high degree) of position determination due to its small frictional coefficient and little position error, as compared to a conventional slide guide system. As described above, the

linear motor may include the coil **411** and the magnetic rail **431b**. The magnetic rail **431b** is linearly located on the carrier **431**, and a plurality of the coils **411** may be located at an inner side of the chamber **101** and separated from the magnetic rail **431b** by a certain distance (e.g., a gap) so as to face the magnetic rail **431b**. Because the magnetic rail **431b** is located at the carrier **431** instead of the coil **411**, the carrier **431** may be operable without power being supplied thereto. In this regard, the coil **411** may be formed (or located) in an atmosphere (ATM) box in an air atmosphere, and the carrier **431** to which the magnetic rail **431b** is attached may be moved in the chamber **101** maintained in vacuum.

[0204] Hereinafter, the first conveyer unit **410** and the transfer unit **430** are described in detail.

[0205] Referring to FIGS. 4 and 7, the first conveyer unit **410** conveys (or transports) the electrostatic chuck **432** that fixes (or attaches to) the substrate **2** and the carrier **431** that conveys (or transports) the electrostatic chuck **432**. In this regard, the first conveyer unit **410** includes the coil **411**, the guide members **412**, the upper magnetically suspended (e.g., magnetic levitation) bearings **413**, the side magnetically suspended (e.g., magnetic levitation) bearings **414**, and the gap sensors **415** and **416**.

[0206] The coil **411** and the guide members **412** are formed (or located) inside the upper housing **104**. The coil **411** is formed (or located) in an upper portion of the upper housing **104**, and the guide members **412** are respectively formed on (or located at) both inner sides of the upper housing **104**.

[0207] The guide members **412** guide the carrier **431** to move in a direction. In this regard, the guide members **412** are formed to pass through the deposition unit **100**.

[0208] In particular, the guide members **412** accommodate both sides of the carrier **431** to guide the carrier **431** to move along in the direction of arrow A illustrated in FIG. 3. In this regard, the guide member **412** may include a first accommodation part **412a** disposed below the carrier **431**, a second accommodation part **412b** disposed above the carrier **431**, and a connection part **412c** that connects the first accommodation part **412a** and the second accommodation part **412b**. An accommodation groove **412d** is formed by the first accommodation part **412a**, the second accommodation part **412b**, and the connection part **412c**. Both sides of the carrier **431** are respectively accommodated in the accommodation grooves **412d**, and the carrier **431** is moved along the accommodation grooves **412d**.

[0209] The side magnetically suspended (e.g., magnetic levitation) bearings **414** are each located at (or in) the connection part **412c** of the guide member **412** so as to respectively correspond to both sides of the carrier **431**. The side magnetically suspended (e.g., magnetic levitation) bearings **414** form (or cause) a distance between the carrier **431** and the guide member **412** so that the carrier **431** is moved along the guide members **412** in non-contact with the guide members **412**. That is, a repulsive force R1 occurring between the side magnetically suspended (e.g., magnetic levitation) bearing **414** on the left side of FIG. 7 and the carrier **431**, which is a magnetic material, and a repulsive force R2 occurring between the side magnetically suspended (e.g., magnetic levitation) bearing **414** on the right side in FIG. 7 and the carrier **431**, which is a magnetic material, maintain equilibrium, and thus, there is a constant (or substantially constant) distance between the carrier **431** and the respective parts of the guide member **412**.

[0210] Each upper magnetically suspended (e.g., magnetic levitation) bearing **413** may be located at (or in) the second accommodation part **412b** of the guide member **412** so as to be above the carrier **431**. The upper magnetically suspended (e.g., magnetic levitation) bearings **413** enable the carrier **431** to be moved along the guide members **412** in non-contact with the first and second accommodation parts **412a** and **412b** and with a distance (or a gap) therebetween maintained constant (or substantially constant). That is, a repulsive force (or alternatively an attractive force) R3 occurring between the upper magnetically suspended bearing **413** and the carrier **431**, which is a magnetic material, and gravity G maintain equilibrium, and thus, there is a constant (or substantially constant) distance between the carrier **431** and the respective guide members **412**.

[0211] Each guide member **412** may further include gap sensors **415** and **416**. The gap sensors **415** and **416** may measure a distance between the carrier **431** and the guide member **412**. Referring to FIG. 7, the gap sensor **415** may be disposed in the first accommodation part **412a** so as to correspond to a bottom portion of the carrier **431**. The gap sensor **415** disposed in the first accommodation part **412a** may measure a distance between the first accommodation part **412a** and the carrier **431**. The gap sensor **416** may be disposed at a side of the side magnetically suspended bearing **414**. The gap sensor **416** may measure a distance between a side surface of the carrier **431** and the side magnetically suspended bearing **414**. The present invention is not limited to the above example and the gap sensor **416** may be disposed in the connection part **412c**.

[0212] Magnetic forces of the upper and side magnetically suspended (e.g., magnetic levitation) bearings **413** and **414** may vary according to values measured by the gap sensors **415** and **416**, and thus, distances between the carrier **431** and the respective guide members **412** may be adjusted in real time. That is, a precise transfer of the carrier **431** may be feedback controlled using the upper and side magnetically suspended (e.g., magnetic levitation) bearings **413** and **414** and the gap sensors **415** and **416**.

[0213] Hereinafter, the second conveyer unit **420** and the transfer unit **430** are described in detail.

[0214] Referring back to FIG. 4, the second conveyer unit **420** returns the electrostatic chuck **432** from which the substrate **2** has been separated in the unloading unit **300** and the carrier **431** that carries the electrostatic chuck **432** to the loading unit **200**. In this regard, the second conveyer unit **420** includes the coil **421**, the roller guides **422**, and the charging track **423**.

[0215] In particular, the coil **421**, the roller guides **422**, and the charging track **423** may be positioned at an inner surface of the lower housing **103**. For example, the coil **421** and the charging track **423** may be located at a top inner surface of the lower housing **103**, and the roller guides **422** may be located at both inner sides of the lower housing **103**. In this regard, like the coil **411** of the first conveyer unit **410**, the coil **421** may be located in an ATM box.

[0216] Also, like the first conveyer unit **410**, the second conveyer unit **420** also includes the coil **421**, and the coil **421** may be combined with the magnetic rail **431b** of the main body part **431a** of the carrier **431** to constitute a driving unit, and herein the driving unit may be a linear motor. The carrier **431** may be moved by the linear motor along a direction opposite to the direction of arrow A illustrated in FIG. 3.

[0217] The roller guides **422** guide the carrier **431** to move in a direction. In this regard, the roller guides **422** are formed (e.g., located or arranged) to pass through the deposition unit **100**. In particular, the roller guides **422** support cam followers **431f** (see FIG. 7) respectively formed on both sides of the carrier **431** to guide the carrier **431** to move along a direction opposite to the direction of arrow A illustrated in FIG. 3. That is, the carrier **431** is moved with the cam followers **431f** disposed on both sides of the carrier **431** respectively rotating along the roller guides **422**. In this regard, the cam followers **431f** are utilized as bearings used to accurately repeat a particular operation. In an embodiment, a plurality of the cam followers **431f** are formed on a side surface of the carrier **431** and serve as a wheel for conveying the carrier **431** in the second conveyer unit **420**. A detailed description of the cam followers **431f** is not provided herein.

[0218] The second conveyer unit **420** is used in a process of returning the carrier **431** from which the substrate **2** has been separated and not in a process of depositing an organic material on the substrate **2**, and thus, position accuracy (or positional accuracy) thereof is not as needed as by the first conveyer unit **410**. Therefore, magnetic suspension (e.g., magnetic levitation) is applied to the first conveyer unit **410** that requires high position accuracy to thereby obtain position accuracy, and a conventional roller method is applied to the second conveyer unit **420** that requires relatively low position accuracy, thereby reducing manufacturing costs and simplifying a structure of an organic layer deposition apparatus. Although not illustrated in FIG. 4, the magnetic suspension may also be applied to the second conveyer unit **420**, as in the first conveyer unit **410**.

[0219] The organic layer deposition assembly **100-1** of the organic layer deposition apparatus **1** according to the present embodiment may further include cameras **170** and sensors **180** for an aligning process. In detail, the cameras **170** may align in real time a first alignment mark formed in the frame **135** of the patterning slit sheet **130** and a second alignment mark formed on the substrate **2**. In this regard, the cameras **170** are positioned for a more accurate view in the chamber **101** maintained in vacuum during deposition. For this, the cameras **170** may be installed in respective camera accommodation units **171** in an atmospheric state.

[0220] Because the substrate **2** and the patterning slit sheet **130** are spaced apart from each other by a certain distance (e.g., a gap), distances between the substrate **2** and the patterning slit sheet **130** that are located at different positions are measured using the cameras **170**. For this operation, the organic layer deposition assembly **100-1** of the organic layer deposition apparatus **1** may include the sensors **180**. In this regard, the sensors **180** may be confocal sensors. The confocal sensors may scan an object to be measured by using laser beams that rotate at a high speed by using a scanning mirror and measure a distance to the object by using fluorescent or reflected rays emitted by the laser beams. The confocal sensors may measure a distance by sensing a boundary interface between different media.

[0221] The use of the cameras **170** and the sensors **180** enables real-time measuring of a distance between the substrate **2** and the patterning slit sheet **130** and thus aligning the substrate **2** and the patterning slit sheet **130** in real-time, and thus position accuracy (or positional accuracy) of a pattern may be improved (e.g., significantly improved).

[0222] FIG. 5 is a perspective view illustrating deposition source nozzles **121** for forming pattern layers, and FIG. 6 is a

perspective view illustrating deposition source nozzles **121'** for forming common layers. Organic layer deposition assemblies for forming pattern layers are pattern layer deposition assemblies (for example, see organic layer deposition assemblies **100-5** to **100-9** of FIG. 13) and thus will be referred to as such hereinafter, and organic layer deposition assemblies for forming common layers are common layer deposition assemblies **100-1** to **100-4**, **100-10**, and **100-11** and thus will be referred to as such hereinafter.

[0223] Referring to FIG. 5, the pattern layer deposition assembly **100-5** includes three deposition sources **110** and three deposition source nozzle units **120**, and each of the deposition source nozzle units **120** includes one deposition source nozzle **121** at its center. The deposition material **115** that has been vaporized in the deposition source **110** passes through the deposition source nozzle unit **120** and is then moved toward the substrate **2**. As described above, each deposition source nozzle unit **120** has one deposition source nozzle **121**, and in a single pattern layer deposition assembly **100-5** according to one embodiment, three deposition sources **110** are arranged along a scan direction of the substrate **2**, and ultimately, a plurality of deposition source nozzles **121** are arranged along the scan direction of the substrate **2** in the pattern layer deposition assembly **100-5**. In this regard, if a plurality of the deposition source nozzles **121** are arranged along the X-axis direction, an interval between each of the deposition source nozzles **121** and the patterning slit **131** may vary and in this case, a shadow may be formed by a deposition material ejected from a deposition source nozzle that is located relatively far from the patterning slit **131**. Accordingly, forming only one deposition source nozzle **121** in the X-axis direction as in the present embodiment may contribute to a reduction (e.g., substantial decrease or reduction) in the formation of shadows. In addition, because the deposition source nozzles **121** are arranged along the scan direction, even when a flux difference occurs between individual deposition source nozzles, the flux difference may be offset and thus deposition uniformity may be maintained constant (or substantially constant).

[0224] In addition, although not illustrated in FIG. 5, among three deposition sources **110** located in the pattern layer deposition assembly **100-5**, deposition sources at opposite ends may be used to deposit a host material and the middle deposition source may be used to deposit a dopant material. As described above, an organic layer deposition apparatus according to an embodiment of the present invention may include both a deposition source for depositing a host material and a deposition source for depositing a dopant material so as to concurrently deposit a host material and a dopant material on the substrate **2**, and thus a process is quickly performed and device efficiency may also be improved.

[0225] Referring to FIG. 6, a deposition source nozzle unit **120'** is located at a side of a deposition source **110'**, for example, a side of the deposition source **110'** facing the substrate **2**. In addition, the deposition source nozzle unit **120'** includes a plurality of deposition source nozzles **121'** arranged along the X-axis direction (that is, a direction perpendicular to the scan direction of the substrate **2**). In one embodiment, the deposition source nozzles **121'** may be formed equidistant from each other, and according to another embodiment, distances between adjacent deposition source nozzles **121'** may decrease toward opposite ends of the deposition source nozzle unit **120'**. A deposition material vapor-

ized in the deposition source **110'** may pass through the deposition source nozzles **121'** of the deposition source nozzle unit **120'** to move toward the substrate **2** on which the deposition material is to be deposited. As described above, in forming a common layer, the deposition source nozzles **121'** are formed along the X-axis direction (that is, a direction perpendicular to the scan direction of the substrate **2**), and thus a thickness uniformity of common layers may be improved.

**[0226]** In one embodiment, the patterning slit sheet **130** may be located between the deposition source **110** and the substrate **2**. The patterning slit sheet **130** may further include a frame having a shape similar to a window frame. The patterning slit sheet **130** includes the plurality of patterning slits **131** arranged along the X-axis direction. The deposition material **115** that has been vaporized in the deposition source **110** passes through the deposition source nozzle unit **120** and the patterning slit sheet **130** and is then moved toward the substrate **2**. In this regard, the patterning slit sheet **130** may be formed using the same method as that used to form an FMM, in particular, a stripe-type mask. For example, the patterning slit sheet **130** may be formed by etching. For example, a total number of patterning slits **131** may be more than a total number of deposition source nozzles **121**.

**[0227]** In one embodiment, the deposition source **110** and the deposition source nozzle unit **120** combined thereto may be spaced apart from the patterning slit sheet **130** by a certain distance (e.g., a gap).

**[0228]** As described above, deposition is performed while the organic layer deposition assembly **100-1** is moved relative to the substrate **2**. In order for the organic layer deposition assembly **100-1** to be moved relative to the substrate **2**, the patterning slit sheet **130** is located spaced apart from the substrate **2** by a certain distance (e.g., a gap).

**[0229]** In a conventional deposition method using an FMM, deposition is typically performed with the FMM in close contact with a substrate in order to prevent formation of shadows on the substrate. However, when the FMM is formed in close contact with the substrate, defects due to the contact between the substrate and the FMM may occur. In addition, because it is difficult to move the mask with respect to the substrate, the mask and the substrate have the same size. Accordingly, the mask becomes larger as the size of a display device increases. However, it is difficult to form a large mask.

**[0230]** To address these problems, in the organic layer deposition assembly **100-1** according to the present embodiment, the patterning slit sheet **130** is formed spaced apart by a certain distance (e.g., a gap) from the substrate **2** on which a deposition material is to be deposited.

**[0231]** According to the present embodiment, deposition may be performed while a mask formed smaller than a substrate is moved with respect to the substrate, and thus, it is relatively easy to manufacture the mask. In addition, defects due to contact between the substrate and the mask may be avoided. In addition, because it is unnecessary to closely contact the substrate with the mask during a deposition process, a manufacturing speed may be improved.

**[0232]** In one embodiment, referring to FIG. 4, the camera **170** may align a first mark formed on the frame **135** of the patterning slit sheet **130** and a second mark (not shown) formed on the substrate **2** in real-time. The sensor **180** may be a confocal sensor. As described above, since a distance between the substrate **2** and the patterning slit sheet **130** is measurable in real time using the camera **170** and the sensor **180**, the substrate **2** may be aligned with the patterning slit

sheet **130** in real time, whereby position accuracy of a pattern may be significantly improved.

**[0233]** The organic layer deposition assemblies **100-1** of the apparatus **1** for organic material deposition according to an embodiment of the present invention may further include a specially designed shielding member **140**, i.e., a tooling shutter **140'** (see FIG. 9) for controlling the thickness of an organic material layer formed on the substrate **2**. Detailed description thereof is given below.

**[0234]** In more detail, characteristics of an organic light-emitting device largely depend on the thickness of an organic material layer. Therefore, to manufacture an organic light-emitting display apparatus with excellent quality, a tooling operation for correcting thicknesses of all organic material layers before forming the organic material layers is required. Here, the tooling operation refers to an operation for depositing an organic material to a desired thickness by depositing the organic material to a substrate having no devices deposited thereon (e.g., a TFT) at a set or predetermined deposition rate, measuring the thickness of the deposited organic material by using an analyzing device for measuring thickness, such as an ellipsometer, and changing a tooling factor (T/F) of the organic material or adjusting the deposition rate based on the measured thickness. Here, the T/F refers to control parameters in a tooling operation based on a ratio between a thickness of an organic material layer actually measured by a sensor and a target thickness of the organic material layer.

**[0235]** However, if a tooling operation is performed on an organic material layer to be formed on a substrate using the method in the related art, it is necessary to perform a tooling operation for each organic material layer to be formed, each deposition source, or each assembly. In other words, it is necessary to perform a tooling operation for each of the organic materials on a one-by-one basis, and thus a significant period of time is taken therefor. For example, in the case of the apparatus for organic layer deposition shown in FIG. 1, in total, there are eleven organic layer deposition assemblies that are arranged and each of the organic layer deposition assemblies includes three deposition sources. It is necessary to perform 33 tooling operations in total on all of the deposition sources. Furthermore, since it is necessary to form organic material layers on glass substrates and analyze the same, it is necessary to invest in materials for deposition and analyzing devices for the tooling operation. Therefore, the method of performing tooling operations in the related art deteriorates production efficiency and raises material costs and investment costs.

**[0236]** To resolve these problems, the apparatus for organic layer deposition further includes the tooling shutter **140'** to control thicknesses of organic material layers formed on the substrate **2**, wherein a plurality of organic material layers are formed on a single substrate and a tooling operation is performed on a plurality of deposition sources at once.

**[0237]** FIG. 8 is a schematic perspective view of the tooling shutter **140'** while the deposition unit **100** of FIG. 3 is depositing an organic material layer, and FIG. 9 is a schematic perspective view showing the tooling shutter **140'** while the deposition unit **100** is in a tooling operation.

**[0238]** FIGS. 8 and 9 show three organic layer deposition assemblies, assuming that the first organic layer deposition assembly **100-1** and the third organic layer deposition assembly **100-3** are organic layer deposition assemblies for depos-

iting a common layer and the second organic layer deposition assembly 100-2 is an organic layer deposition assembly for depositing a pattern layer.

[0239] In this case, the first organic layer deposition assembly 100-1 and the third organic layer deposition assembly 100-3 for depositing a common layer respectively include first tooling shutters 141. A plurality of tooling slits 141a may be formed in the first tooling shutter 141 to have a long shape extending in a direction in which a substrate moves. An average of thicknesses of a plurality of organic material layers formed on a substrate is obtained by using the plurality of tooling slits 141a, and a tooling operation for correcting thicknesses of the organic material layers is performed based on the average.

[0240] The first tooling shutters 141 are formed to be able to move in organic layer deposition assemblies, and the first tooling shutters 141 may be arranged in front of the deposition sources 110 only when a tooling operation is performed. In other words, during deposition of an organic material layer, as shown in FIG. 8, as the first tooling shutters 141 are a set or predetermined distance apart from the deposition sources 110 in a direction, a path in which the deposition material 115 moves is formed, and thus the deposition material 115 emitted by the deposition source 110 is deposited on the substrate 2. During a tooling operation, as shown in FIG. 9, the first tooling shutters 141 are arranged in front of the deposition sources 110, and thus organic materials evaporated at the deposition sources 110 pass through the first tooling shutters 141 and form a set or predetermined pattern layer on the substrate 2.

[0241] Here, the tooling slits 141a of the first tooling shutter 141 arranged in each of the organic layer deposition assemblies may be formed to be somewhat offset to one another. In other words, the tooling slits 141a of the first organic layer deposition assembly 100-1 may not be arranged on the same lines as the tooling slits 141a of the third organic layer deposition assembly 100-3, and thus an organic material evaporated at the first organic layer deposition assembly 100-1 and an organic material evaporated at the third organic layer deposition assembly 100-3 may be deposited at different regions on a substrate.

[0242] The second organic layer deposition assembly 100-2 for deposition of a pattern layer includes a second tooling shutter 142. Tooling slits 142a for measuring thicknesses of organic material layers may be arranged at two opposite ends of the second tooling shutter 142 to have a long shape extending in a direction in which a substrate moves.

[0243] As described above, an average of thicknesses of a plurality of pattern layers formed on a substrate is obtained by using the tooling slits 142a formed at two opposite ends of the second tooling shutter 142, and a tooling operation for correcting thicknesses of the organic material layers is performed based on the average.

[0244] The second tooling shutter 142 is formed to be able to move in the organic layer deposition assembly and the second tooling shutter 142 may be arranged in front of the deposition source 110 only when a tooling operation is performed. In other words, during deposition of an organic material layer, as shown in FIG. 8, as the second tooling shutter 142 is a set or predetermined distance apart from, the deposition source 110 in a direction, a path in which the deposition material 115 moves is formed, and thus the deposition material 115 emitted by the deposition source 110 is deposited on the substrate 2. During a tooling operation, as shown in FIG.

9, the second tooling shutter 142 is arranged in front of the deposition source 110, and thus organic materials evaporated at the deposition source 110 pass through the second tooling shutter 142 and form a set or predetermined pattern layer on the substrate 2.

[0245] Here, the width of the tooling slit 142a of the second tooling shutter 142 may be greater than the width of the patterning slit 131 of the patterning slit sheet 130. Although the width of the patterning slit 131 of the patterning slit sheet 130 is about several hundred  $\mu\text{m}$  and is similar to the thickness of a pattern layer, the minimum measurable thickness of a pattern layer is about 2  $\mu\text{m}$ , and thus it is necessary to form the tooling slit 142a of the second tooling shutter 142 for a tooling operation to have a width greater than that of the patterning slit 131 of the patterning slit sheet 130.

[0246] As described above, by forming a plurality of linear pattern layers on a single substrate, a plurality of organic material layers are formed on the single substrate and a tooling operation may be performed with respect to a plurality of deposition sources at the same time.

[0247] Hereinafter, a method by which the apparatus for organic layer deposition corrects thickness will be described in more detail.

[0248] FIG. 10 is a schematic view showing that, during the tooling operation of FIG. 9, an organic material layer is formed as a substrate passes through the first organic layer deposition assembly 100-1. FIG. 11 is a schematic view showing that, during the tooling operation of FIG. 9, an organic material layer is formed as the substrate passes through the second organic layer deposition assembly 100-2. FIG. 12 is a schematic view showing that, during the tooling operation of FIG. 9, an organic material layer is formed as the substrate passes through the third organic layer deposition assembly 100-3.

[0249] A comparable method of correcting thickness will be described below. First, organic material films are formed by depositing organic materials for film formation on respective deposition glass substrates by using an arbitrary T/F and an arbitrary deposition rate. Next, thicknesses of the organic material films are measured by using an analyzing device for measuring thickness, such as an ellipsometer. Target thicknesses are fulfilled by adjusting the T/F based on the measured thicknesses. Next, to determine whether the corrected T/F is accurate, it is necessary to perform tooling operations on the respective organic materials again, and, even after the formation of the organic material films, it is necessary to perform tooling operations once more in every 100 to 120 depositions.

[0250] However, by using the method of correcting thicknesses according to an embodiment of the present invention, films are formed by using a single substrate in a single pass instead of forming films with respect to each of the deposition sources. In other words, when the tooling shutters 140' are arranged as shown in FIG. 9 and the substrate 2 moves in the direction of arrow A in a tooling operation, deposition materials accommodated in the first organic layer deposition assembly 100-1 are patterned onto the substrate 2 as the substrate 2 passes through the first organic layer deposition assembly 100-1, and thus a first tooling pattern layer 2a is formed on the substrate 2, as shown in FIG. 10. Here, the first tooling pattern layer 2a is patterned by the tooling shutter 140' of the first organic layer deposition assembly 100-1.

[0251] Here, the substrate 2 continues to move and, when the substrate 2 passes through the second organic layer depo-

sition assembly **100-2**, deposition materials accommodated in the second organic layer deposition assembly **100-2** are patterned onto the substrate **2**, and thus a second tooling pattern layer **2b** is formed on the substrate **2**, as shown in FIG. **11**. The second tooling pattern layer **2b** is patterned by patterning slits **131b** of the patterning slit sheet **130** of the second organic layer deposition assembly **100-2**.

[0252] Here, the substrate **2** continues to move and, when the substrate **2** passes through the third organic layer deposition assembly **100-3**, deposition materials accommodated in the third organic layer deposition assembly **100-3** are patterned onto the substrate **2**, and thus a third tooling pattern layer **2c** is formed on the substrate **2**, as shown in FIG. **12**. The third tooling pattern layer **2c** is patterned by the tooling shutters **140'** of the third organic layer deposition assembly **100-3**.

[0253] As described above, according to an embodiment of the present invention, a tooling operation is performed by using a single substrate in a single pass without forming films on different substrates according to respective deposition sources, and a period of time may be reduced as compared to a case in which thicknesses of films are measured at each of the substrates, and thus productivity may be improved. Furthermore, a unit price of a product may be reduced due to a reduction of investment based on a reduction of substrate costs and the reduced number of analyzing devices. Therefore, mass production may be significantly improved.

[0254] FIG. **13** is a schematic perspective view of deposition assemblies including deposition sources, according to an embodiment of the present invention. Referring to FIG. **13**, an organic layer deposition apparatus according to an embodiment of the present invention includes eleven organic layer deposition assemblies **100-1**, **100-2** through **100-11**. In addition, each of the deposition assemblies **100-1**, **100-2** through **100-11** includes three deposition sources. For example, the deposition assembly **100-1** may include three deposition sources **110-1a**, **110-1b**, and **110-1c**, and the deposition assembly **100-2** may include three deposition source **110-2a**, **110-2b**, and **110-2c**.

[0255] The organic layer deposition assemblies **100-1**, **100-2** through **100-11** include, as described above, the common layer deposition assemblies **100-1**, **100-2**, **100-3**, **100-4**, **100-10**, and **100-11** and the pattern layer deposition assemblies **100-5** through **100-9**.

[0256] The common layer deposition assemblies **100-1**, **100-2**, **100-3**, **100-4**, **100-10**, and **100-11** may form common layers of an organic layer (for example, see OLED of FIG. **26**). That is, the deposition sources **110-1a**, **110-1b**, and **110-1c** of the common layer deposition assembly **100-1** may include a deposition material for forming a hole injection layer, and deposition sources **110-2a**, **110-2b**, and **110-2c** of the common layer deposition assembly **100-2** may include a deposition material for forming an intermediate layer, deposition sources **110-3a**, **110-3b**, and **110-3c** of the common layer deposition assembly **100-3** may include a deposition material for forming a hole transport layer, and deposition sources **110-4a**, **110-4b**, and **110-4c** of the common layer deposition assembly **100-4** may include a deposition material for forming a hole injection layer. In addition, deposition sources **110-10a**, **110-10b**, and **110-10c** of the common layer deposition assembly **100-10** may include a deposition material for forming an electron transport layer, and deposition sources **110-11a**, **110-11b**, and **110-11c** of the common layer deposition assembly **100-11** may include a deposition material for forming an electron injection layer. The deposited layers

formed by the common layer deposition assemblies **100-1**, **100-2**, **100-3**, **100-4**, **100-10**, and **100-11** may be commonly formed regardless of sub-pixels. Accordingly, a patterning slit sheet, that is, an open mask **136** that has one patterning slit, may be formed on (e.g., located on or above) deposition sources of the common layer deposition assemblies **100-1**, **100-2**, **100-3**, **100-4**, **100-10**, and **100-11**.

[0257] Each of the pattern layer deposition assemblies **100-5**, **100-6**, **100-7**, **100-8**, and **100-9** may form a patterned layer of the organic layer **62** for a corresponding sub-pixel. That is, deposition sources **110-5a**, **110-5b**, and **110-5c** of the pattern layer deposition assembly **100-5** may include a deposition material for forming an auxiliary layer of red and green sub-pixels, deposition sources **110-6a**, **110-6b**, and **110-6c** of the pattern layer deposition assembly **100-6** may include a deposition material forming an auxiliary layer for a red sub-pixel, deposition sources **110-7a**, **110-7b**, and **110-7c** of the pattern layer deposition assembly **100-7** may include a deposition material for forming a red emission layer, deposition sources **110-8a**, **110-8b**, and **110-8c** of the pattern layer deposition assembly **100-8** may include a deposition material for forming a green emission layer, and deposition sources **110-9a**, **110-9b**, and **110-9c** of the pattern layer deposition assembly **100-9** may include a deposition material for forming a blue emission layer.

[0258] The patterning slit sheet **130** having the patterning slits **131** may be located over deposition sources of the pattern layer deposition assemblies **100-5**, **100-6**, **100-7**, **100-8**, and **100-9**.

[0259] The present invention is not limited thereto, and an organic layer deposition apparatus according to other embodiments of the present invention may include two or more deposition assemblies, and each of the deposition assemblies may include one or more deposition sources. In addition, a deposition material included in a deposition source may vary according to the structure of a device.

[0260] FIG. **14** is a schematic plan view of examples of correction slit sheets. When thicknesses of patterning layers are measured, correction slit sheets **231**, **232**, **233**, **234**, and **235** replace a patterning slit sheet (for example, see **130** of FIG. **4**) of each pattern layer deposition assembly (for example, see **100-5**, **100-6**, **100-7**, **100-8**, and **100-9** of FIG. **137**) to be located on a second stage (for example, see **160** of FIG. **4**). That is, the correction slit sheets **231**, **232**, **233**, **234**, and **235** may be located on the respective second stages **160** of pattern layer deposition assemblies (see **100-5**, **100-6**, **100-7**, **100-8**, and **100-9** of FIG. **13**).

[0261] Each of the correction slit sheets **231**, **232**, **233**, **234**, and **235** may respectively include (or have) a plurality of correction slits **231a**, **232a**, **233a**, **234a**, and **235a**. A lengthwise direction of each of the correction slits **231a**, **232a**, **233a**, **234a**, and **235a** may be parallel to the conveying (or transporting) direction of the substrate **2**, that is, a first direction A, and locations of the correction slits **231a**, **232a**, **233a**, **234a**, and **235a** along a second direction perpendicular to the first direction A are different from each other. That is, the correction slits **231a**, **232a**, **233a**, **234a**, and **235a** may be formed such that they are offset in the second direction perpendicular to the first direction A. That is, locations of the correction slits **231a**, **232a**, **233a**, **234a**, and **235a** of the correction slit sheets **231**, **232**, **233**, **234**, and **235** located on the pattern layer deposition assemblies **100-5**, **100-6**, **100-7**, **100-8**, and **100-9** may be different from each other with respect to the first direction A. Accordingly, when deposition

materials that have passed through the correction slits **231a**, **232a**, **233a**, **234a**, and **235a** are deposited on the substrate **2** to form pattern layers, the formed pattern layers do not overlap.

[0262] When thicknesses of pattern layers are measured, among deposition sources of the pattern layer deposition assemblies **100-5**, **100-6**, **100-7**, **100-8**, and **100-9**, deposition sources **110-5a**, **110-6a**, **110-7a**, **110-8a**, and **110-9a** are operated, and operations of the other deposition sources **110-5b**, **110-5c**, **110-6b**, **110-7b**, **110-7c**, **110-8b**, **110-8c**, **110-9b**, and **110-9c** are stopped, or shutters (not shown in FIG. 14) are used to prevent their deposition materials from reaching correction substrates, and in this state, a first correction substrate is conveyed (e.g., transported) in the first direction A and deposition materials of the operated deposition sources **110-5a**, **110-6a**, **110-7a**, **110-8a**, and **110-9a** are allowed to be deposited on the first correction substrate. When the first correction substrate has completely passed through the deposition units, deposition sources **110-5b**, **110-6b**, **110-7b**, **110-8b**, and **110-9b** are operated, and while deposition materials of deposition sources other than the deposition sources **110-5b**, **110-6b**, **110-7b**, **110-8b**, and **110-9b** are prevented from reaching the second correction substrate, the second correction substrate is conveyed (or transported) in the first direction A to allow deposition materials ejected from deposition sources to be deposited on the second correction substrate. When the second correction substrate has completely passed through the deposition units, deposition sources **110-5c**, **110-6c**, **110-7c**, **110-8c**, and **110-9c** are operated, and while deposition materials of deposition sources other than the deposition sources **110-5c**, **110-6c**, **110-7c**, **110-8c**, and **110-9c** are prevented from reaching the second correction substrate, the third correction substrate is conveyed (or transported) in the first direction A to allow deposition materials ejected from deposition sources to be deposited on the third correction substrate.

[0263] As described above, when a deposition process is performed to measure thicknesses of pattern layers by using the correction slit sheets **231**, **232**, **233**, **234**, and **235**, the number of correction substrates used to measure a thickness of a pattern layer may be the same as the number of deposition sources included in a pattern layer deposition assembly. For example, because each of the pattern layer deposition assemblies **100-5**, **100-6**, **100-7**, **100-8**, and **100-9** includes, as illustrated in FIG. 7, three deposition sources, three correction substrates are used to measure thicknesses of pattern layers of the deposition sources **110-5a**, **110-5b**, **110-5c**, . . . , **110-9a**, **110-9b**, and **110-9c**.

[0264] For example, the use of the correction slit sheets **231**, **232**, **233**, **234**, and **235** enable thicknesses of pattern layers formed by using deposition sources to be measured with three correction substrates. That is, when the correction slit sheets **231**, **232**, **233**, **234**, and **235** having the correction slits **231a**, **232a**, **233a**, **234a**, and **235a** that are offset from each other are not used, a total of 15 correction substrates, which is the same number as the number of deposition sources **110-5a**, **110-5b**, **110-5c**, . . . , **110-9a**, **110-9b**, **110-9c**, may be required to measure thicknesses of pattern layers formed by using deposition sources. However, because the correction slit sheets **231**, **232**, **233**, **234**, and **235** according to an embodiment of the present invention include the correction slits **231a**, **232a**, **233a**, **234a**, and **235a** that are offset from each other, pattern layers formed by deposition sources of the pattern layer deposition assemblies **100-5**, **100-6**, **100-**

**7**, **100-8**, and **100-9** do not overlap. Accordingly, when the number of correction substrates is the same as the number (three in the embodiment illustrated in FIG. 13) of deposition sources of the pattern layer deposition assemblies **100-5**, **100-6**, **100-7**, **100-8**, and **100-9**, thicknesses of pattern layers formed by deposition sources of the pattern layer deposition assemblies **100-5**, **100-6**, **100-7**, **100-8**, and **100-9** may be measured. By doing so, time and costs for the measurement and correction of thicknesses of pattern layers may be reduced.

[0265] Lengths of the correction slits **231a**, **232a**, **233a**, **234a**, and **235a** may all be the same in the embodiment illustrated in FIG. 14.

[0266] FIG. 15 is a schematic plan view of other examples of correction slit sheets.

[0267] Correction plates **231b**, **232b**, **233b**, **234b**, and **235b** are respectively located or positioned on surfaces of the correction slit sheets **331**, **332**, **333**, **334**, and **335** to block at least a portion of a deposition material ejected from each deposition source.

[0268] The correction plates **231b**, **232b**, **233b**, **234b**, and **235b** are shaped such that the height (or width) of the correction plates is maximum at a location near the respective centers of the correction slit sheets **331**, **332**, **333**, **334**, and **335**, and the height (or width) decreases as respective portions of the correction plates approach edges of the respective correction slit sheets. In other words, a gap between each pair of the correction plates **231b**, **232b**, **233b**, **234b**, and **235b** is at a minimum at a location near central portions of the respective correction slit sheets **331**, **332**, **333**, **334**, and **335**, and the gap between the pair of the correction plates becomes wider as portions of the correction plates **231b**, **232b**, **233b**, **234b**, and **235b** approach respective end portions of the correction slit sheets **331**, **332**, **333**, **334**, and **335**. As illustrated in FIG. 15, the correction plates **231b**, **232b**, **233b**, **234b**, and **235b** may have a shape of a circular arc or cosine.

[0269] The correction plates **231b**, **232b**, **233b**, **234b**, and **235b** having such a shape may result in a greater amount of shield deposition material at the center of a correction slit sheet than at an end of the correction slit sheet.

[0270] According to another embodiment of the present invention, instead of blocking a deposition material by using the correction plates **231b**, **232b**, **233b**, **234b**, and **235b**, correction slits of a correction slit sheet may be formed to have different lengths to block a deposition material. That is, correction slits of each correction slit sheet may have greater lengths away from the center of the correction slit sheet.

[0271] FIG. 16 is a schematic perspective view of deposition assemblies each including a deposition unit, according to an embodiment of the present invention. Referring to FIG. 16, an organic layer deposition apparatus according to an embodiment of the present invention may include 11 deposition assemblies **100-1** through **100-11**. Also, each of the deposition assemblies **100-1** through **100-11** may include three deposition sources. For example, the deposition assembly **100-1** includes three deposition sources **110-1a** through **110-1c**, and the deposition assembly **100-2** may include three deposition sources **110-2a** through **110-2c**.

[0272] Each of the deposition assemblies **100-1** through **100-4**, **100-10** and **100-11** may form a common layer in an organic layer **62** of FIG. 26. In other words, the deposition sources **110-1a** through **110-1c** of the deposition assembly **100-1** may include a deposition material for forming a hole injection layer, the deposition sources **110-2a** through **110-2c**

of the deposition assembly 100-2 may include a deposition material for forming an injection layer, deposition sources 110-3a through 110-3c of the deposition assembly 100-3 may include a deposition material for forming a hole transport layer, and deposition sources 110-4a through 110-4c of the deposition assembly 100-4 may include a deposition material for forming a hole injection layer. Also, deposition sources 110-10a through 110-10c of the deposition assembly 100-10 may include a deposition material for forming an electron transport layer, and deposition sources 110-11a through 110-11c of the deposition assembly 100-11 may include a deposition material for forming an electron injection layer. Deposition layers formed by some of the deposition assemblies 100-1, 100-2, 100-3, 100-4, 100-10, and 100-11 may be commonly formed regardless of a sub-pixel. Accordingly, a patterning slit sheet, i.e., an open mask, including one patterning slit may be disposed on the deposition sources of the deposition assemblies 100-1, 100-2, 100-3, 100-4, 100-10, and 100-11.

[0273] Each of other deposition assemblies 100-5, 100-6, 100-7, 100-8, and 100-9 may form a patterned layer according to sub-pixels in the organic layer 62. In other words, deposition sources 110-5a through 110-5c of the deposition assembly 100-5 may include a deposition material for forming an assistant layer of red and green sub-pixels, deposition sources 110-6a through 110-6c of the deposition assembly 100-6 may include a deposition material for forming an assistant layer of a red sub-pixel, deposition sources 110-7a through 110-7c of the deposition assembly 100-7 may include a deposition material for forming a red emission layer, deposition sources 110-8a through 110-8c of the deposition assembly 100-8 may include a deposition material for forming a green emission layer, and deposition sources 110-9a through 110-9c of the deposition assembly 100-9 may include a deposition material for forming a blue emission layer.

[0274] The patterning slit sheet 130 including the plurality of patterning slits 131 may be located at the deposition sources of the deposition assemblies 100-5, 100-6, 100-7, 100-8, and 100-9.

[0275] However, the present invention is not limited thereto and the organic layer deposition apparatus according to an embodiment of the present invention may include two or more deposition assemblies and each of the deposition assemblies may include one or more deposition sources. Also, any suitable one of various types of deposition materials may be included in a deposition source according to a device structure.

[0276] FIGS. 17 and 18 are schematic plan views that illustrate operations of modification shutters 141-1 through 141-11, according to an embodiment of the present invention. FIG. 17 is a plan view before the modification shutters 141-1 through 141-11 are respectively located on the deposition assemblies 100-1 through 100-11, and FIG. 18 is a plan view after the modification shutters 141-1 through 141-11 are respectively located on the deposition assemblies 100-1 through 100-11.

[0277] As shown in FIG. 18, the modification shutters 141-1 through 141-11 may be located between the deposition source 110 and the patterning slit sheet 130, and may respectively include openings 142-1 through 142-11 configured to allow the deposition material 115 to pass-through towards the patterning slit sheet 130. The openings 142-1 through 142-11 may be elongated in a first direction A. The openings 142-1

through 142-11 of the modification shutters 141-1 through 141-11 are parallel to the first direction A in lengths, but have different locations. In other words, the openings 142-1 through 142-11 may be configured to be offset from each other along a direction (second direction) perpendicular to the first direction A. Accordingly, when the deposition materials that passed through the openings 142-1 through 142-11 form pattern layers deposited on a modifying substrate 2, the pattern layers formed by the deposition assemblies 100-1 through 100-11 do not overlap each other. Because there are a total of 11 deposition assemblies 100-1 through 100-11 in FIGS. 17 and 18, 11 un-overlapping pattern layers may be formed through the openings 142-1 through 142-11 along the second direction.

[0278] Generally, the deposition unit 100 of FIG. 1 includes m organic layer deposition assemblies, and each of the m organic layer deposition assemblies may include n deposition sources and one modification shutter. Here, m and n may each be a natural number greater than or equal to 2.

[0279] When a thickness of an organic layer is measured, the (n-1)th deposition source may be activated, and a modifying substrate (e.g., the substrate on which organic layers are to be deposited for thickness measurement) may be transferred (or transported) in a first direction and a deposition material from the activated (n-1)th deposition source may be deposited on the modifying substrate while deposition materials from other deposition sources other than the (n-1)th deposition source are blocked from reaching the modifying substrate. When the modifying substrate is out of a deposition unit, the (n)th deposition source is activated, and the modifying substrate is transferred in the first direction and a deposition material from the activated (n)th deposition source may be deposited on the modifying substrate while deposition materials of other deposition sources other than the (n)th deposition source are blocked from reaching the modifying substrate. Referring to FIGS. 17 and 18, the modification shutters 141-1 through 141-11 may be used to measure thicknesses of organic layers formed on a substrate.

[0280] For example, the modification shutters 141-1 through 141-11 are located at one side of the deposition sources 110-1a, 110-1b, 110-1c, . . . , 110-11a, 110-11b, 110-11c as shown in FIG. 17 before measuring the thicknesses of organic layers, and when the thicknesses are to be measured, the modification shutters 141-1 through 141-11 are arranged on the deposition sources 110-1a, 110-1b, 110-1c, . . . , 110-11a, 110-11b, 110-11c as shown in FIG. 18. Then, a deposition process may be performed as the modifying substrate 2 moves along the first direction A. When the deposition process is performed on the modifying substrate 2, the deposition sources 110-1a, 110-2a, . . . , 110-11a nearest to the modifying substrate 2 before transference from among the deposition sources 110-1a, 110-1b, 110-1c, . . . , 110-11a, 110-11b, 110-11c are activated and the deposition materials of the deposition sources 110-1a, 110-2a, . . . , 110-11a are deposited on the modifying substrate 2. Here, deposition sources 110-1b, 110-1c, 110-2b, 110-2b, . . . , 110-11b, 110-11c other than the deposition sources 110-1a, 110-2a, . . . , 110-11a may be stopped from being activated or blocked by the shielding member 140 of FIG. 3 such that the deposition materials thereof do not reach the modifying substrate 2.

[0281] After the deposition processes are all performed by the deposition sources 110-1a, 110-2a, . . . , 110-11a, deposition sources 110-1b, 110-2b, . . . , 110-11b adjacent to the deposition sources 110-1a, 110-2a, . . . , 110-11a are acti-

vated, and other deposition sources **110-1a**, **110-1c**, **110-2a**, **110-2c**, . . . , **110-11a**, **110-11c** are stopped from being activated or blocked by the shielding member **140** such that the deposition materials thereof do not reach the modifying substrate **2**.

[0282] When the deposition process for measuring the thickness of the organic layer is performed as such, the number of modifying substrates **2** equal to the number of deposition sources included in one deposition assembly is used to measure the thickness of the organic layer. For example, referring to FIGS. **17** and **18**, because three deposition sources are included in each of the deposition assemblies **100-1** through **100-11**, three modifying substrates **2** may be used to measure the thickness of the organic layer formed by each of the deposition sources **110-1a**, **110-1b**, **110-1c**, . . . , **110-11a**, **110-11b**, **110-11c**.

[0283] By using such modification shutters **141-1** through **141-11**, the thicknesses of the organic layers deposited on the three modifying substrates **2** by each deposition sources may be measured. In other words, when the modification shutters **141-1** through **141-11** having the openings **142-1** through **142-11** that are offset from each other are not used, the number of modifying substrates **2** equal to the number of the deposition sources **110-1a**, **110-1b**, **110-1c**, . . . , **110-11a**, **110-11b**, **110-11c** may be required to measure the thickness of the organic layer formed by each deposition source. However, because the modification shutter **141-1** through **141-11** respectively include the openings **142-1** through **142-11** that are offset from each other, the organic layers formed by the deposition sources of the deposition assemblies **100-1** through **100-11** do not overlap each other. Thus, the thicknesses of the organic layers formed by the deposition sources of the deposition assemblies **100-1** through **100-11** may be measured by using the number of modifying substrates **2** equal to the number of the deposition sources included in each of the deposition assemblies **100-1** through **100-11**. Accordingly, times required to measure and compensate for the thickness of the organic layer may be reduced, and costs for measuring and compensating for the thickness of the organic layer may be reduced.

[0284] FIG. **19** is a schematic perspective view of an organic layer deposition assembly **700** according to another embodiment of the present invention, FIG. **20** is a schematic side-sectional view of the organic layer deposition assembly **700** of FIG. **19**, and FIG. **21** is a schematic plan sectional view of the organic layer deposition assembly **700** of FIG. **19**.

[0285] Referring to FIGS. **19** to **21**, the organic layer deposition assembly **700** according to the present embodiment includes a deposition source **710**, a deposition source nozzle unit **720**, a shielding assembly (e.g., a barrier assembly or a barrier plate assembly) **730**, and a patterning slit sheet **750**.

[0286] The deposition source **710** includes a crucible **711** that is filled with a deposition material **715** and a heater **712** that heats the crucible **711** so as to vaporize the deposition material **715** toward the deposition source nozzle unit **720**. The deposition source nozzle unit **720** is located at a side of the deposition source **710**. The deposition source nozzle unit **720** includes a plurality of deposition source nozzles **721** arranged along an X-axis direction.

[0287] In addition, the shielding plate assembly **730** is located at a side of the deposition source nozzle unit **720**. The shielding plate assembly **730** includes a plurality of shielding plates (e.g., barrier plates) **731**, and a shielding frame **732** located outside (e.g., around or surrounding) the shielding

plates **731**. The shielding plates **731** may be arranged parallel to each other along the X-axis direction. In this regard, the shielding plates **731** may be equidistant from each other. In addition, the shielding plates **731** may extend along a YZ plane, as illustrated in FIG. **19**, and may be rectangular. The shielding plates **731** may divide (e.g., define) a space between the deposition source nozzle unit **720** and the patterning slit sheet **750** into a plurality of deposition spaces S. That is, in the organic layer deposition assembly **700** according to the present embodiment, due to the shielding plates **731**, as illustrated in FIG. **19**, each of the deposition source nozzles **721** through which deposition materials are emitted has a deposition space S. As described above, because the shielding plates **731** divide a space between the deposition source nozzle unit **720** and the patterning slit sheet **750** into a plurality of deposition spaces S, a deposition material ejected from one deposition source nozzle **721** may not be mixed with a deposition material ejected from another deposition source nozzle **721** and may pass through a patterning slit **751** of the patterning slit sheet **750** to be deposited on a substrate **2** attached to an electrostatic chuck **600**. That is, the shielding plates **731** may prevent deposition materials ejected (or discharged) through the respective deposition source nozzles **721** from being dispersed and may guide their movement paths, that is, guide them to move in a Z-axis direction.

[0288] As described above, the shielding plates **731** may provide linearity of a deposition material, and thus, the size of shadows formed on the substrate **2** may be reduced (e.g., substantially reduced), and accordingly, it is possible to keep the organic layer deposition assembly **700** spaced apart from the substrate **2** by a certain distance (e.g., a gap).

[0289] In one embodiment, the patterning slit sheet **750** may be located between the deposition source **710** and the substrate **2**. The patterning slit sheet **750** may further include a frame **755** having a shape similar to a window frame. The patterning slit sheet **750** includes patterning slits **751** arranged in the X-axis direction with regions or spacers **752** therebetween. The deposition material **715** that has been vaporized in the deposition source **710** passes through the deposition source nozzle unit **720** and the patterning slit sheet **750** and then moves toward the substrate **2**.

[0290] FIG. **22** is a schematic perspective view of an organic layer deposition assembly **800** according to another embodiment of the present invention.

[0291] Referring to FIG. **22**, an organic layer deposition assembly **800** according to the present embodiment includes a deposition source **810**, a deposition source nozzle unit **820**, a first shielding plate assembly (e.g., a first barrier plate assembly) **830**, a second shielding plate assembly (e.g., a second barrier plate assembly) **840**, and a patterning slit sheet **850**. In this regard, detailed structures of the deposition source **810**, the first shielding plate assembly **830**, and the patterning slit sheet **850** are substantially the same as described with reference to the embodiment illustrated in FIG. **19**, and thus, description thereof is not presented herein. The organic layer deposition assembly **800** according to the present embodiment is different from the organic layer deposition assembly **700** according to the previous embodiment in that the second shielding plate assembly **840** is located at one side of the first shielding plate assembly **830**.

[0292] For example, the second shielding plate assembly **840** includes a plurality of second shielding plates (e.g., barrier plates) **841**, and a second shielding frame **842** located outside (e.g., around or surrounding) the second shielding

plates **841**. The second shielding plates **841** may be arranged in parallel to each other along the X-axis direction. In this regard, the second shielding plates **841** may be equidistant from each other. In addition, the respective second shielding plates **841** may be formed to be (arranged in) parallel to a YZ plane in FIG. 22, that is, may be formed (e.g., arranged or oriented) in a direction perpendicular to the X-axis direction.

[0293] The first shielding plates **831** and the second shielding plates **841** arranged as described above may divide a space between the deposition source nozzle unit **820** and the patterning slit sheet **850**. That is, due to the first shielding plates **831** and the second shielding plates **841**, the deposition space is divided into a plurality of deposition spaces respectively corresponding to the deposition source nozzles **821** through which deposition materials are ejected.

[0294] In this regard, the second shielding plates **841** may be located correspondingly to the first shielding plates **831**, respectively. In other words, the respective second shielding plates **841** are aligned with the respective first shielding plates **831** such that the respective second shielding plates **841** are parallel to the respective first shielding plates **831**. That is, a first shielding plate and a second shielding plate corresponding thereto may be located on the same plane. Although in FIG. 22, widths (or thicknesses) of the first shielding plates **831** in the X-axis direction appear to be the same as X-axis direction widths of the second shielding plates **841**, embodiments of the present invention are not limited thereto. That is, the second shielding plates **841** that require fine alignment with patterning slits **851** may be formed to be relatively thin, and the first shielding plates **831** that do not require fine alignment with the patterning slits **851** may be formed to be relatively thick, enabling ease of manufacturing thereof. Regions or spacers **852** are between the patterning slits **851**.

[0295] FIG. 23 is a schematic perspective view of an organic layer deposition assembly **900** according to another embodiment of the present invention.

[0296] Referring to FIG. 23, the organic layer deposition assembly **900** according to the present embodiment includes a deposition source **910**, a deposition source nozzle unit **920**, and a patterning slit sheet **950**.

[0297] The deposition source **910** includes a crucible **911** that is filled with the deposition material **915** and a heater **912** that heats the crucible **911** so as to vaporize the deposition material **915** toward the deposition source nozzle unit **920**. The deposition source nozzle unit **920** is located at one side of the deposition source **910**.

[0298] The deposition source nozzle unit **920** includes a plurality of deposition source nozzles **921** arranged along the Y-axis direction. In one embodiment, the patterning slit sheet **950** and a frame **955** may be further located between the deposition source **910** and a substrate **2** attached to an electrostatic chuck **600**, and the patterning slit sheet **950** may have a plurality of patterning slits **951** and spacers (or regions) **952** arranged along the X-axis direction. The deposition source **910** and the deposition source nozzle unit **920** may be connected to the patterning slit sheet **950** by a connection member **935**.

[0299] The present embodiment is different from the previous embodiments in the arrangement of the deposition source nozzles **921** included in the deposition source nozzle unit **920**. The difference is described in detail below.

[0300] The deposition source nozzle unit **920** is located at one side of the deposition source **910**, for example, a side of the deposition source **910** toward the substrate **2**. In addition,

the deposition source nozzle unit **920** includes deposition source nozzles **921** arranged along the Y-axis direction (that is, the scan direction of the substrate **2**). In this regard, the deposition source nozzles **921** may be equidistant from each other. The deposition material **915** that has been vaporized in the deposition source **910** passes through the deposition source nozzle unit **920** and is then moved toward the substrate **2**. Ultimately, in an organic layer deposition assembly **900**, the deposition source nozzles **921** are arranged along the scan direction of the substrate **2**. In this regard, if deposition source nozzles **921** are arranged along the X-axis direction, an interval between each of the deposition source nozzles **921** and the patterning slit **951** may vary and in this case, a shadow may be formed due to a deposition material ejected from a deposition source nozzle that is located relatively far from the patterning slit **951**. Accordingly, forming only one deposition source nozzle **921** along the X-axis direction as in the present embodiment may contribute to a substantial decrease in the formation of shadows. In addition, because the deposition source nozzles **921** are arranged along the scan direction, even when a flux difference occurs between individual deposition source nozzles, the flux difference may be offset and thus deposition uniformity may be maintained constant (or substantially constant).

[0301] Hereinafter, a structure of an organic layer formed using an organic layer deposition apparatus according to an embodiment of the present invention is described in more detail.

[0302] FIG. 24 is a schematic view illustrating equidistant patterning slits **131** of the patterning slit sheet **130** of an organic layer deposition apparatus, and FIG. 25 is a schematic view of an organic layer that is formed by using the patterning slit sheet **130** of FIG. 24.

[0303] FIGS. 24 and 25 illustrate the patterning slit sheet **130** in which the patterning slits **131** are equidistant to each other. That is, in FIG. 24, the patterning slits **131** satisfy the following condition:  $I_1=I_2=I_3=I_4$ .

[0304] In this embodiment, an incident angle of a deposition material discharged along a center line C of a deposition space S is substantially perpendicular to the substrate **2**. Thus, an organic layer  $P_1$  formed using the deposition material that has passed through a patterning slit **131a** has a shadow with a minimum (or reduced) size, and a right-side shadow  $SR_1$  and a left-side shadow  $SL_1$  are formed symmetrical to (or symmetrically with) each other.

[0305] However, a critical incident angle  $\theta$  of the deposition material that passes through patterning slits located farther from the center line C of the deposition space S gradually increases, and thus, the critical incident angle  $\theta$  of the deposition material that passes through an outermost patterning slit **131e** is approximately  $55^\circ$ . Accordingly, the deposition material is incident at an inclination with respect to the patterning slit **131e**, and an organic layer  $P_5$  formed using the deposition material that has passed through the patterning slit **131e** has the largest shadow. For example, a left-side shadow  $SL_5$  is larger than a right-side shadow  $SR_5$ .

[0306] That is, as the critical incident angle  $\theta$  of the deposition material increases, the size of the shadow also increases. For example, the size of the shadow at a position farther from the center line C of the deposition space S increases. In addition, the critical incident angle  $\theta$  of the deposition material increases as a distance between the center line C of the deposition space S and the respective patterning slits increases. Thus, organic layers formed using the depo-

sition material that passes through the patterning slits located farther from the center line C of the deposition space S have a larger shadow size. For example, of the shadows on both sides of the respective organic layers, the size of the shadow at a position farther from the center line C of the deposition space S is larger than that of the other.

[0307] That is, referring to FIG. 25, the organic layers formed on the left side of the center line C of the deposition space S have a structure in which a left hypotenuse (a slanted side on the left between top and bottom sides) is larger than a right hypotenuse (a slanted side on the right between top and bottom sides), and the organic layers formed on the right side of the center line C of the deposition space S have a structure in which a right hypotenuse (e.g., a right slanted side) is larger than a left hypotenuse (e.g., a left slanted side).

[0308] Also, in the organic layers formed on the left side of the center line C of the deposition space S, the length of the left hypotenuse (e.g., the left slanted side) increases towards the left. In the organic layers formed on the right side of the center line C of the deposition space S, the length of the right hypotenuse (e.g., the right slanted side) increases towards the right. Consequently, the organic layers formed in the deposition space S may be formed symmetrical to each other about the center line C of the deposition space S.

[0309] This structure will now be described in more detail.

[0310] The deposition material that passes through a patterning slit 131b passes through the patterning slit 131b at a critical incident angle of  $\theta_b$ , and an organic layer P<sub>2</sub> formed using the deposition material that has passed through the patterning slit 131b has a left-side shadow having a size of SL<sub>2</sub>. Likewise, the deposition material that passes through a patterning slit 131c passes through the patterning slit 131c at a critical incident angle of  $\theta_c$ , and an organic layer P<sub>3</sub> formed using the deposition material that has passed through the patterning slit 131c has a left-side shadow having a size of SL<sub>3</sub>. Likewise, the deposition material that passes through a patterning slit 131d passes through the patterning slit 131d at a critical incident angle of  $\theta_d$ , and an organic layer P<sub>4</sub> formed using the deposition material that has passed through the patterning slit 131d has a left-side shadow having a size of SL<sub>4</sub>. Likewise, the deposition material that passes through the patterning slit 131e passes through the patterning slit 131e at a critical incident angle of  $\theta_e$ , and an organic layer P<sub>5</sub> formed using the deposition material that has passed through the patterning slit 131e has a left-side shadow having a size of SL<sub>5</sub>.

[0311] In this regard, the critical incident angles satisfy the following condition:  $\theta_b < \theta_c < \theta_d < \theta_e$ , and thus, the sizes of the shadows of the organic layers also satisfy the following condition:  $SL_1 < SL_2 < SL_3 < SL_4 < SL_5$ .

[0312] FIG. 26 is a schematic cross-sectional view of an active matrix-type organic light-emitting display apparatus that is manufactured using an organic layer deposition apparatus according to an embodiment of the present invention.

[0313] Referring to FIG. 26, the active matrix organic light-emitting display apparatus 10 according to the present embodiment is formed on a substrate 2. The substrate 2 may be formed of a transparent material, for example, glass, plastic, or metal. An insulating layer 51, such as a buffer layer, is formed on an entire surface of the substrate 2. The insulating layer 51 may be omitted in other embodiments.

[0314] A thin film transistor (TFT) and an organic light-emitting diode (OLED) are disposed on the insulating layer 51, as illustrated in FIG. 17.

[0315] A semiconductor active layer 52 is formed on an upper surface of the insulating layer 51 in a set or predetermined pattern. A gate insulating layer 53 is formed to cover the semiconductor active layer 52. The semiconductor active layer 52 may include a p-type or n-type semiconductor material.

[0316] A gate electrode 54 of the TFT is formed in a region of the gate insulating layer 53 corresponding to the semiconductor active layer 52. An interlayer insulating layer 55 is formed to cover the gate electrode 54. After the interlayer insulating layer 55 is formed, the interlayer insulating layer 55 and the gate insulating layer 53 are etched by, for example, dry etching, to form contact holes respectively exposing parts of the semiconductor active layer 52.

[0317] Source/drain electrodes 56 and 57 are formed on the interlayer insulating layer 55 to contact the semiconductor active layer 52 through the respective contact holes. A passivation layer 58 is formed to cover the source/drain electrodes 56 and 57, and is etched to expose a part of one of the source/drain electrodes 56 and 57. An insulating layer 59 may be further formed on the passivation layer 58 so as to planarize the passivation layer 58.

[0318] In addition, the OLED displays image information (e.g., set or predetermined image information) by emitting red, green, or blue light according to current. The OLED includes a first electrode 61 located on the passivation layer 58. The first electrode 61 is electrically connected to the exposed source/drain electrodes 56 and 57 of the TFT.

[0319] A pixel defining layer 60 is formed to cover the first electrode 61. An opening is formed in the pixel-defining layer 60, and an organic layer 62, including an emission layer (EML), is formed in a region defined by the opening. A second electrode 63 is formed on the organic layer 62.

[0320] The pixel-defining layer 60, which defines individual pixels, may be formed of an organic material. The pixel-defining layer 60 also planarizes the surface of a region of the substrate 2, in which the first electrode 61 is formed, and in particular, the surface of the insulating layer 59.

[0321] The first electrode 61 and the second electrode 63 are electrically insulated from each other, and respectively apply voltages of opposite polarities to the organic layer 62 to induce light emission.

[0322] The organic layer 62, including an EML, may be formed of a low-molecular weight organic material or a high-molecular weight organic material. When a low-molecular weight organic material is used, the organic layer 62 may have a single or multi-layer structure including a hole injection layer (HIL), a hole transport layer (HTL), the EML, an electron transport layer (ETL), and/or an electron injection layer (EIL). Non-limiting examples of available organic materials may include copper phthalocyanine (CuPc), N,N'-di(naphthalene-1-yl)-N,N'-diphenyl-benzidine (NPB), and tris-8-hydroxyquinoline aluminum (Alq3).

[0323] The organic layer 62, including an EML, may be formed using the organic layer deposition apparatus according to embodiments of the present invention (for example, see organic layer deposition apparatus 1 of FIG. 1). That is, an organic layer deposition apparatus is disposed spaced apart by a set or predetermined distance from a substrate on which the deposition material is to be deposited, wherein the organic layer deposition apparatus includes a deposition source that discharges a deposition material, a deposition source nozzle unit that is located at one side of the deposition source, wherein the deposition source nozzle unit includes a plurality

of deposition source nozzles formed therein, and a patterning slit sheet that faces the deposition source nozzle unit, wherein the patterning slit sheet includes a plurality of patterning slits formed therein. Then, while one of the organic layer deposition apparatus (see 1 of FIG. 1) or a substrate (see 2 of FIG. 1) is relatively moved, the deposition material ejected from the organic layer deposition apparatus (for example, see organic layer deposition apparatus 1 of FIG. 1) is deposited on the substrate (for example, see substrate 2 of FIG. 1).

**[0324]** After the organic layer 62 is formed, the second electrode 63 may be formed by the same (or substantially the same) deposition method as used to form the organic layer 62.

**[0325]** The first electrode 61 may function as an anode, and the second electrode 63 may function as a cathode. Alternatively, the first electrode 61 may function as a cathode, and the second electrode 63 may function as an anode. The first electrode 61 may be patterned to correspond to individual pixel regions, and the second electrode 63 may be formed to cover all the pixels (e.g., cover substantially an entire area of the substrate).

**[0326]** The first electrode 61 may be formed as a transparent electrode or a reflective electrode. Such a transparent electrode may be formed of indium tin oxide (ITO), indium zinc oxide (IZO), zinc oxide (ZnO), or indium oxide ( $\text{In}_2\text{O}_3$ ). Such a reflective electrode may be formed by forming a reflective layer from silver (Ag), magnesium (Mg), aluminum (Al), platinum (Pt), palladium (Pd), gold (Au), nickel (Ni), neodymium (Nd), iridium (Ir), chromium (Cr), or a compound thereof, and forming a layer of ITO, IZO, ZnO, or  $\text{In}_2\text{O}_3$  on the reflective layer. The first electrode 61 may be formed by forming a layer by, for example, sputtering, and then patterning the layer by, for example, photolithography.

**[0327]** The second electrode 63 may also be formed as a transparent electrode or a reflective electrode. When the second electrode 63 is formed as a transparent electrode, the second electrode 63 may be used as a cathode. To this end, such a transparent electrode may be formed by depositing a metal having a low work function, such as lithium (Li), calcium (Ca), lithium fluoride/calcium (LiF/Ca), lithium fluoride/aluminum (LiF/Al), aluminum (Al), silver (Ag), magnesium (Mg), or a compound thereof, on a surface of the organic layer 62, and forming an auxiliary electrode layer or a bus electrode line thereon from ITO, IZO, ZnO,  $\text{In}_2\text{O}_3$ , or the like. When the second electrode 63 is formed as a reflective electrode, the reflective electrode may be formed by depositing Li, Ca, LiF/Ca, LiF/Al, Al, Ag, Mg, or a compound thereof on the entire surface of the organic layer 62. The second electrode 63 may be formed using the same deposition method as used to form the organic layer 62 described above.

**[0328]** The organic layer deposition apparatuses according to the embodiments of the present invention described above may be applied to form an organic layer or an inorganic layer of an organic TFT, and to form layers from various suitable materials.

**[0329]** According to embodiments of the present invention, an organic layer deposition apparatus that is suitable for use in a mass production of devices on a large substrate, enables high-definition patterning, enables a thickness of an organic layer to be corrected in a reduced time, leading to a high operation rate of the organic layer deposition apparatus, and enables costs for the correction of a thickness of an organic layer to be reduced to decrease manufacturing costs of the organic light-emitting display apparatus, a method of manufacturing an organic light-emitting display apparatus by using

the same, and an organic light-emitting display apparatus manufactured using the method, may be provided.

**[0330]** As described above, the one or more embodiments of the present invention provide organic layer deposition apparatuses that are suitable for use in the mass production of a large substrate and enable high-definition patterning, methods of manufacturing organic light-emitting display apparatuses by using the same, and organic light-emitting display apparatuses manufactured using the methods. Although some embodiments of the present invention have been shown and described, it would be appreciated by those skilled in the art that changes may be made to these embodiments without departing from the principles and spirit of the present invention, the scope of which is defined in the claims and their equivalents.

What is claimed is:

1. A method of manufacturing an organic light-emitting display apparatus by using an organic layer deposition apparatus for forming an organic layer on a substrate, the method comprising:

attaching a substrate to a transfer unit in a loading unit; transporting, into a chamber, the transfer unit to which the substrate is attached, by using a first conveyer unit passing through the chamber;

depositing deposition materials discharged from a plurality of organic layer deposition assemblies to form organic layers on the substrate while the substrate is moved relative to the organic layer deposition assemblies, the organic layer deposition assemblies being in the chamber and spaced apart from the substrate;

separating from the transfer unit the substrate on which the depositing has been completed in an unloading unit; and transporting the transfer unit from which the substrate is separated to the loading unit by using a second conveyer unit installed to pass through the chamber, wherein each of the plurality of organic layer deposition assemblies comprises:

a plurality of deposition sources, each of the plurality of deposition sources being configured to discharge a corresponding one of a plurality of deposition materials; and

a deposition source nozzle unit at a side of each of the deposition sources, and comprising one or more deposition source nozzles,

the organic layer deposition assemblies comprise a plurality of common layer deposition assemblies for forming a common layer and a plurality of pattern layer deposition assemblies for forming a pattern layer,

each of the pattern layer deposition assemblies further comprises a correction slit sheet comprising a plurality of correction slits,

the correction slits of the pattern layer deposition assemblies are offset with respect to each other along a first direction in which the substrate is transported, and

the substrate is spaced apart from the organic layer deposition apparatus so as to be relatively movable with respect to the organic layer deposition apparatus, and the deposition materials discharged from the deposition sources pass through respective said correction slit sheets and are deposited in a pattern on the substrate.

2. The method of claim 1, wherein the chamber accommodates the organic layer deposition assemblies with which deposition is continuously performed on the substrate.

3. The method of claim 1, wherein the transfer unit circulates between the first conveyer unit and the second conveyer unit.

4. The method of claim 1, wherein the first conveyer unit and the second conveyer unit are arranged in parallel and one on top of the other.

5. The method of claim 1, wherein a length of patterning slit sheets of the organic layer deposition assemblies in at least one of the first direction or a second direction perpendicular to the first direction is less than that of the substrate.

6. The method of claim 1, wherein each of the correction slits extends in the first direction.

7. The method of claim 1, wherein locations of the correction slits of the correction slit sheets in different pattern layer deposition assemblies are different from each other in the first direction.

8. The method of claim 1, wherein a length of the correction slits of the correction slit sheets increases as the correction slits are farther away from respective centers of the correction slit sheets.

9. The method of claim 1, further comprising

a correction plate located at a side of a corresponding one of the correction slit sheets and shielding at least a portion of the deposition material discharged from the deposition source.

10. The method of claim 9, wherein

a width of the correction plate decreases from a center towards an edge of a corresponding one of the correction slit sheets.

11. The method of claim 10, wherein the correction plate has a shape of a circular arc or cosine.

12. The method of claim 9, wherein a width of the correction plate at a region corresponding to a center of a corresponding one of the correction slit sheets is greater than that at an edge of the correction plate.

13. The method of claim 9, wherein the correction plate has a shape such that the deposition material is better shielded at a center of the correction slit sheet than at an edge of the correction slit sheet.

14. An organic light-emitting display apparatus comprising:

a substrate;

a plurality of thin film transistors on the substrate and each comprising a semiconductor active layer, a gate electrode insulated from the semiconductor active layer, and source and drain electrodes each contacting the semiconductor active layer;

a plurality of pixel electrodes respectively on the thin film transistors;

a plurality of organic layers respectively on the plurality of pixel electrodes; and

a counter electrode on the plurality of organic layers,

wherein a length of a slanted side between a top side and a bottom side of at least one of the organic layers on the substrate farther from a center of a deposition region is greater than lengths of slanted sides of other ones of the organic layers formed closer to the center of the deposition region, and

the at least one of the organic layers on the substrate is a linearly-patterned organic layer formed using the method of claim 1.

15. A method of manufacturing an organic light-emitting display device by using an organic layer deposition apparatus for forming an organic layer on a substrate, the method comprising:

attaching the substrate to a transfer unit in a loading unit; transporting, into a chamber, the transfer unit to which the substrate is attached, by using a first conveyer unit passing through the chamber;

forming organic layers by depositing deposition materials discharged from a plurality of organic layer deposition assemblies on the substrate while the substrate is spaced apart from and moved relative to the organic layer deposition assemblies in the chamber;

separating the substrate on which the depositing has been completed from the transfer unit in an unloading unit; and

transporting the transfer unit from which the substrate is separated to the loading unit by using a second conveyer unit passing through the chamber,

wherein each of the organic layer deposition assemblies comprises:

a plurality of deposition sources, each of the deposition sources being configured to discharge a corresponding one of the deposition materials;

a deposition source nozzle unit at a side of each of the plurality of deposition sources and comprising one or more deposition source nozzles;

a patterning slit sheet facing the deposition source nozzle unit and comprising one or more patterning slits; and

a modification shutter located between the plurality of deposition sources and the patterning slit sheet and having an opening that is configured to allow the corresponding ones of the deposition materials from the deposition sources to pass-through towards the patterning slit sheet,

wherein the openings of adjacent ones of the modification shutters are offset from each other along a second direction perpendicular to a first direction in which the substrate is transported, and

the deposition materials discharged from the plurality of deposition sources pass through the patterning slit sheet and are deposited on the substrate in patterns.

16. The method of claim 15, wherein the chamber comprises the plurality of the organic layer deposition assemblies, and wherein deposition is sequentially performed on the substrate by using each of the plurality of the organic layer deposition assemblies.

17. The method of claim 15, wherein the transfer unit is moved between the first conveyer unit and the second conveyer unit.

18. The method of claim 15, wherein the first conveyer unit and the second conveyer unit are arranged in parallel to each other above and below.

19. The method of claim 15, wherein the patterning slit sheet of the organic layer deposition assembly is formed smaller than the substrate in at least one of a first direction or the second direction perpendicular to the first direction.

20. The method of claim 15, wherein the opening of each of the modification shutters is elongated in the first direction.

21. The method of claim 15, wherein locations of the openings of the modification shutters are different from each other.

**22.** The method of claim **15**, wherein, when thicknesses of the plurality of organic layers are measured, a modifying substrate is transferred through the organic layer deposition apparatus, and

the modification shutter is located between the plurality of deposition sources and the patterning slit sheet such that the deposition materials are deposited on the modifying substrate by passing through the opening of the modification shutter.

**23.** The method of claim **22**, wherein the deposition unit comprises  $m$  organic layer deposition assemblies, each of the  $m$  organic layer deposition assemblies comprises  $n$  deposition sources, and each of the  $m$  organic layer deposition assemblies comprises one modification shutter, wherein  $m$  and  $n$  are natural numbers.

**24.** The method of claim **23**, wherein, when the thicknesses of the plurality of organic layers are measured, the  $(n-1)$ th deposition source is activated, and the modifying substrate is transferred in the first direction and the deposition material is deposited on the modifying substrate from the activated  $(n-1)$ th deposition source while the deposition materials of the deposition sources other than the  $(n-1)$ th deposition source are blocked from reaching the modifying substrate, and

after the modifying substrate is out of the deposition unit, the  $(n)$ th deposition source is activated, and the modifying substrate is transferred in the first direction and the deposition material is deposited on the modifying substrate from the activated  $(n)$ th deposition source while the deposition materials of the deposition sources other than the  $(n)$ th deposition source are blocked from reaching the modifying substrate.

**25.** An organic light-emitting display device comprising:  
a substrate;

at least one thin film transistor on the substrate and comprising a semiconductor active layer, a gate electrode insulated from the semiconductor active layer, and source and drain electrodes each contacting the semiconductor active layer;

a plurality of pixel electrodes on the at least one thin film transistor;

a plurality of organic layers on the plurality of the pixel electrodes; and

a counter electrode located on the plurality of organic layers,

wherein a length of a slanted side between top and bottom sides of at least one of the plurality of organic layers on the substrate farther from a center of a deposition region is larger than lengths of slanted sides between respective top and bottom sides of other ones of the plurality of organic layers formed closer to the center of the deposition region, and

the at least one of the plurality of organic layers on the substrate is a linearly-patterned organic layer formed using the method of claim **11**.

**26.** A method of using an apparatus for organic layer deposition for forming an organic material layer on a substrate, the method comprising:

transporting into a channel, a transfer unit on which the substrate is fixed by a first conveyer unit that is configured to pass through a chamber;

forming organic layers on the substrate, when a plurality of organic layer deposition assemblies are a set distance apart from the substrate, the substrate being moved relative to the organic layer deposition assemblies and the

organic material layers being formed as deposition materials emitted by the organic layer deposition assemblies are deposited on the substrate; and

transporting the transfer unit from which the substrate is detached back by a second conveyer unit that is configured to pass through the chamber,

wherein the forming of the organic material layers comprises an operation in which, while the substrate for tooling is being transported in the organic layer deposition assemblies, the deposition material is deposited onto the tooling substrate by a first tooling shutter in which one or more tooling slits are formed.

**27.** The method of claim **26**, wherein the first tooling shutter is arranged in each of the plurality of organic layer deposition assemblies, and the tooling slits formed in the first tooling shutters are formed to be at least partially offset to one another.

**28.** The method of claim **27**, wherein the first tooling shutter is arranged in an organic layer deposition assembly for depositing a common layer, among the plurality of organic layer deposition assemblies.

**29.** The method of claim **26**, wherein the first tooling shutter is arranged to cover at least a portion of the substrate only while the tooling substrate is being transported in the organic layer deposition assemblies.

**30.** The method of claim **26**, further comprising an operation in which the substrate is fixed to the transfer unit at a loading unit before the transfer unit is transported by the first conveyer unit; and

an operation in which the substrate, to which deposition is completed, is detached from the transfer unit at an unloading unit before the transfer unit is transported back by the second conveyer unit.

**31.** The method of claim **30**, wherein the transfer unit moves back and forth between the first conveyer unit and the second conveyer unit.

**32.** The method of claim **30**, wherein the first conveyer unit and the second conveyer unit are arranged next to each other in a vertical direction.

**33.** The method of claim **30**, wherein each of the organic layer deposition assemblies comprises:

a deposition source, which emits a deposition material;

a deposition source nozzle unit, which is arranged at one side of the deposition source, the deposition source nozzle unit comprising a plurality of deposition source nozzles; and

a patterning slit sheet, which is arranged to face the deposition source nozzle unit, the patterning slit sheet comprising a plurality of patterning slits arranged in a direction,

wherein the deposition material emitted by the deposition source passes through the patterning slit sheet and is deposited to form a pattern on the substrate.

**34.** The method of claim **33**, wherein, in an organic layer deposition assembly for depositing a pattern layer among the plurality of organic layer deposition assemblies, a second tooling shutter, which is arranged between the deposition nozzle and the patterning slit sheet to cover at least a portion of the substrate and includes tooling slits formed at two opposite ends, is formed.

**35.** The method of claim **34**, wherein a width of the tooling slit of the second tooling shutter is greater than a width of the patterning slit of the patterning slit sheet.

36. The method of claim 33, wherein the patterning slit sheet of the organic layer deposition assembly is formed smaller than the substrate in at least any one of a first direction and a second direction perpendicular to the first direction.

37. An organic light-emitting display apparatus comprising:

a substrate;

at least one thin film transistor on the substrate and comprises a semiconductor active layer, a gate electrode insulated from the semiconductor active layer, and source and drain electrodes each contacting the semiconductor active layer;

a plurality of pixel electrodes on the at least one thin film transistor;

a plurality of organic layers on the plurality of the pixel electrodes; and

a counter electrode on the plurality of organic layers, wherein a length of a slanted side between top and bottom sides of at least one of the plurality of organic layers formed on the substrate farther from a center of a deposition region is larger than lengths of slanted sides between respective top and bottom sides of other ones of the plurality of organic layers closer to the center of the deposition region,

wherein the at least one of the plurality of organic layers formed on the substrate is a linearly-patterned organic layer formed using the method of claim 19.

\* \* \* \* \*

专利名称(译)	有机层沉积设备，使用其制造有机发光显示设备的方法，以及使用该方法制造的有机发光显示设备		
公开(公告)号	<a href="#">US20140014929A1</a>	公开(公告)日	2014-01-16
申请号	US13/938173	申请日	2013-07-09
[标]申请(专利权)人(译)	三星显示有限公司		
申请(专利权)人(译)	三星DISPLAY CO. , LTD.		
当前申请(专利权)人(译)	三星DISPLAY CO. , LTD.		
[标]发明人	LEE SU HWAN SUNG UN CHEOL KIM CHAE WOONG CHOI YOUNG MOOK		
发明人	LEE, SU-HWAN SUNG, UN-CHEOL KIM, CHAE-WOONG CHOI, YOUNG-MOOK		
IPC分类号	H01L51/56 H01L27/32		
CPC分类号	H01L51/56 H01L27/32		
优先权	1020120075138 2012-07-10 KR 1020120076940 2012-07-13 KR 1020120110095 2012-10-04 KR		
其他公开文献	US9496524		
外部链接	<a href="#">Espacenet</a> <a href="#">USPTO</a>		

摘要(译)

有机层沉积设备，通过使用该有机发光显示设备制造有机发光显示设备的方法，以及使用该方法制造的有机发光显示设备。有机层沉积设备包括输送单元，输送单元包括第一和第二输送单元，装载和卸载单元，以及沉积单元。转移单元在第一和第二输送单元之间移动，并且附接到转移单元的基板与沉积单元的多个有机层沉积组件间隔开，同时由第一输送单元转移。有机层沉积组件包括公共层沉积组件和图案层沉积组件。

